

INTRODUCTION

The idea of differential equations was first proposed by Isaac Newton and Gottfried Leibniz during the development of calculus. The term “differential equation” was introduced by Leibniz in 1676. In the 18th century, mathematicians like Euler and Lagrange made significant contributions to the theory of these equations. Over the centuries, research conducted by hundreds of mathematicians, physicists, economists, chemists and other scientists around the world has broadened the range of applications and methods to solve differential equations.

For example, if a particle covers a distance s in time t , then its velocity v and acceleration a can be represented by the differential equations as follows:

$$v = \frac{ds}{dt} \quad \text{and} \quad a = \frac{dv}{dt}$$

To begin our study with this important topic, we will first define differential equation and classify their various types.

4.1 Differential equations: Definition, Order and Degree

An equation that involves at least one derivative of a dependent variable with respect to an independent variable is called a differential equation and this particularly called ordinary differential equation. For example:

$$\begin{array}{lll} \text{(i)} \quad \frac{dy}{dx} + y \cos y = \sin x & \text{(ii)} \quad \frac{d^2 y}{dx^2} + xy \left(\frac{dy}{dx} \right)^2 = 0 & \text{(iii)} \quad \sqrt{\frac{dy}{dx}} = \frac{d^2 y}{dx^2} \\ \text{(iv)} \quad \frac{d^2 y}{dx^2} + 1 = \cos \left(\frac{d^3 y}{dx^3} \right) & \text{(v)} \quad \sqrt{xy} \frac{dy}{dx} + \left(\frac{dy}{dx} \right)^2 = \sin y & \text{(vi)} \quad \frac{d^2 y}{dx^2} + \frac{dy}{dx} = 0 \end{array}$$

The **order** of a differential equation is the order of the highest derivative that appears in the differential equation. For example, the order of the equations (i) and (v) is 1, the order of equations (ii) and (iii) is 2, whereas equation (iv) has order 3. A differential equation of order 1 is called **first-order differential equation**, such as (i) and (v).

The **degree** of a differential equation is the greatest exponent of the highest-order derivative appearing in the differential equation. For example, differential equation (v) is a polynomial in $\frac{dy}{dx}$, and its degree is 2.

4.1.1 Construction of First-Order and Differential Equations from Practical Situations

First-order differential equations model problems where the rate of change of a quantity depends on the quantity itself or on time. For example, motion of a particle, population growth or decay, Newton's law of cooling or heating, electric circuits, economic models and radioactive decay etc.

Example 1 Population Growth/Decay

Solution: The rate of change of population is proportional to the population itself.

Mathematical Model:

Let P represent the population at time t . Since the rate of change of population is proportional to the population at that time, we can write:

$$\frac{dP}{dt} \propto P$$

If k is the constant of proportionality, this becomes:

$$\boxed{\frac{dP}{dt} = kP}$$

This is a first order differential equation.

Observation: From this equation, we observe:

- (i) If $k > 0$, the population increases (growth).
- (ii) If $k < 0$, the population decreases (decay).
- (iii) If $k = 0$, population remains constant.

By solving this differential equation, we can find the population at any specific time t .

Example 2 Temperature Problem (Cooling/Heating Law)

Solution: Let T represent the temperature of a body at time t , and let T_s be the constant temperature of the surrounding medium. According to Newton's law of cooling (or heating), the rate of change of body's temperature with respect to time is proportional to the difference between body's temperature and the surrounding temperature.

Mathematical Model:

$$\frac{dT}{dt} \propto (T_s - T)$$

Introducing a constant of proportionality $k > 0$, the relation becomes:

$$\boxed{\frac{dT}{dt} = k(T_s - T)}$$

This is the required first ordered differential.

Observations: (i) If $T < T_s$, the body is warming up and $\frac{dT}{dt}$ is positive.

(ii) If $T > T_s$, the body is cooling down and $\frac{dT}{dt}$ is negative.

By solving this differential equation, we can find the temperature T in the body at any time t .

Example 3 Inflation/Deflation Problem in Economics

Inflation means the price of goods is increasing over time, while **deflation** means the price of goods is decreasing over time. In this example, we construct a first-order differential equation to describe how the price of a good changes over time due to inflation or deflation.

Solution: Let P represent the price of a good at time t . We assume that the rate of change of price is proportional to the current price.

Mathematical Model:

$$\frac{dP}{dt} \propto P$$

Let k be the constant of proportionality representing the rate of inflation or deflation, then the desired differential equation can be written as:

$$\frac{dP}{dt} = kP$$

Example 4 Flow of Electricity in Series Circuits

In daily life, many problems involve the current flowing in series circuits. Here, we discuss two simple cases connected to first-order differential equations.

(i) Charging a Capacitor Through a Resistor (RC Circuit Model)

Solution: An RC circuit consists of a resistor of resistance R ohms and a capacitor of capacitance C farad connected in a series with a DC voltage source of constant emf V_s volts. The initial current is assumed to be zero (see Figure 4.1).

At time $t = 0$, the switch is closed, and the capacitor begins to charge. Let q be the charge on the capacitor at time t , and I the current flowing through the circuit.

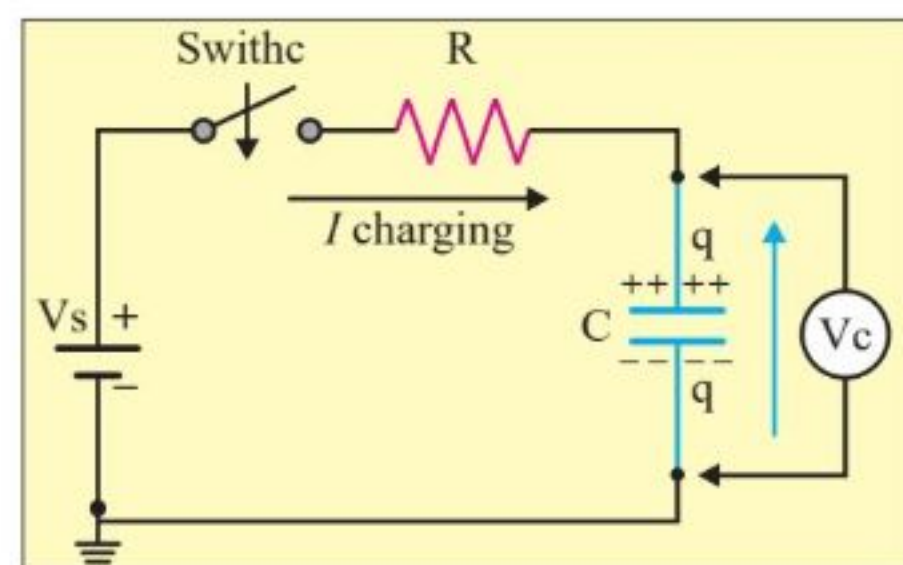

Figure 4.1

Mathematical Model:

The voltage across the capacitor is:

$$V_c = \frac{q}{C}$$

According to Ohm's law, the voltage across the resistor is:

$$V_R = IR$$

By Kirchhoff's voltage law, the sum of voltages across the resistor and capacitor equals to the total voltage from the battery. The source voltage denoted by V_S that is given as:

$$V_S = V_r + V_C$$

$$V_S = \frac{q}{C} + V_R = \frac{q}{C} + IR$$

Substituting $I = \frac{dq}{dt}$, the equation becomes:

$$R \frac{dq}{dt} + \frac{q}{C} = V_S$$

or simply,

$$RC \frac{dq}{dt} = CV_S - q$$

(ii) Charging an Inductor Through a Resistor (RL Circuit Model)

Situation: An RL circuit consists of a resistor of resistance R ohms and an inductor of induction L henries connected in a series with a DC voltage source of constant emf V_S volts. The initial current is assumed to be zero (see Figure 4.2).

At time $t = 0$, the switch is closed and the inductor begins to charge. Let I be the current flowing through the inductor at time t .

Mathematical Model

The voltage across the inductor is:

$$V_L = L \frac{dI}{dt}$$

According to Ohm's law, the voltage across the resistor is:

$$V_R = RI$$

By Kirchhoff's voltage law, the sum of voltages across the resistor and inductor equals to the applied voltage:

$$V_S = V_L + V_R$$

$$L \frac{dI}{dt} + RI = V_S$$

In this way, differential equation is:

$$L \frac{dI}{dt} = V_S - RI$$

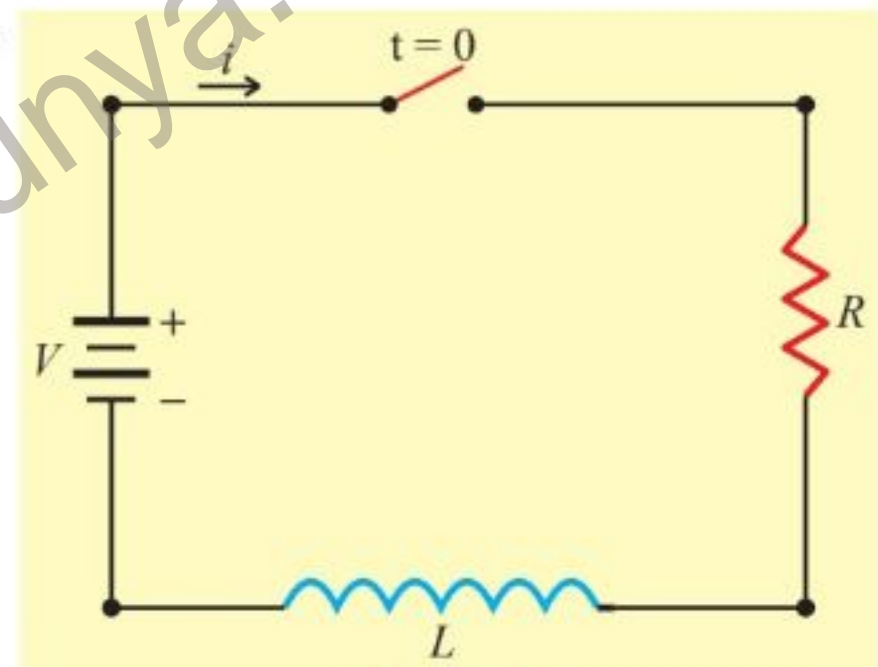

Figure 4.2

EXERCISE 4.1

1. Write the order and degree (if defined) of the following differential equations:

(i) $\frac{d^3 y}{dx^2} + 7 \frac{d^2 y}{dx^2} - 9xy \frac{dy}{dx} + x^2 y = 0$ (ii) $\left(\frac{d^2 y}{dx^2}\right)^3 + \frac{dy}{dx} = 1$

(iii) $\frac{d^2 y}{dx^2} + \sin\left(\frac{dy}{dx}\right) = 0$ (iv) $\frac{dy}{dx} + e^y \sin(x) = 0$

(v) $\cos x \left(\frac{d^2 y}{dx^2}\right)^{\frac{1}{3}} + \frac{dy}{dx} + y = 0$

2. Let A denote the amount of money deposited in a bank at time t , which grows over time with constant compound interest rate $r > 0$. Construct a differential equation which represents the growth of amount over time.

(Hint: The rate of change of amount with respect to time is proportional to amount itself).

3. Let T denote the temperature of a body at time t . Suppose that the effect of the surrounding medium is negligible. Construct a differential equation that represents the temperature of the body at any time t , assuming the body is losing heat due to some internal processes.

4. An object of mass m is thrown vertically upward. Assuming that the air resistance is proportional to its velocity at any time t , construct a differential equation representing the velocity v . Also, deduce the equation in the case when air resistance is negligible.

5. Let N denote the amount of radioactive substance present at time t . Construct a differential equation that models the radioactive decay of the substance.

Hint: (Radioactive decay is a natural process by which an unstable atomic nucleus loses energy by emitting radiation. The rate at which a radioactive substance decays is proportional to the amount of the substance present at any given time).

6. For an RC circuit, recall the differential equation representing the charging of a capacitor. Deduce the differential equation that represents the discharging of the capacitor.
7. For an RL circuit, recall the differential equation representing the charging of an inductor. Deduce the differential equation that represents the discharging of the inductor.

4.2 Solution of First-Order and First-Degree Differential Equations

General form of the first order and first degree differential equations.

$$\frac{dy}{dx} = f(x, y)$$

where f is a function of two variables x and y , defined on some region of the xy -plane. It is always possible to write the above equation in differential form as follows:

$$M(x, y)dx + N(x, y)dy = 0$$

where $M(x, y)$ and $N(x, y)$ are the functions of x and y .

Examples: (i) $\frac{dy}{dx} = \frac{x+y}{y-x}$ or $(x+y)dx + (x-y)dy = 0$

(ii) $\frac{dy}{dx} = -\frac{x}{y}$ or $x dx + y dy = 0$

A solution of a differential equation is a function defined on some interval I that reduces the equation to an identity. A condition of the form

$$y = y_0 \text{ at } x = x_0 \text{ written as } y(x_0) = y_0$$

is called an **initial value condition** or **one point boundary condition**. A differential equation together with an initial value condition is called an **Initial Value Problem (IVP)**.

4.2.1 Separable Differential Equation

A first-order, first-degree differential equation is called **Separable** if it can be written as:

$$\frac{dy}{dx} = g(x)h(y) \quad \text{or} \quad g(x)dx = \frac{1}{h(y)} dy$$

For example, the differential equation $\frac{dy}{dx} = -\frac{x}{y}$ is separable can be written as

$y dy = -x dx$. However, the differential equation $\frac{dy}{dx} = \frac{x+y}{y-x}$ is not separable.

Method to Solve a Separable Differential Equation

Note that the separable differential equation:

$$\frac{dy}{dx} = g(x)h(y)$$

can be written as: $\frac{1}{h(y)} dy = g(x) dx$

Now, integrate both sides:

$$\int \frac{1}{h(y)} dy = \int g(x) dx$$

By solving the integrals on both sides, we obtain the general solution of separable differential equation.

Example 2 Find the general solution of the differential equation $x dx + y dy = 0$.

Solution: The given differential equation is separable. It can be written as:

$$y dy = -x dx$$

Integrating both sides:

$$\begin{aligned} \int y dy &= -\int x dx \\ \Rightarrow \frac{y^2}{2} &= -\frac{x^2}{2} + c \\ \Rightarrow y^2 &= -x^2 + 2c \end{aligned}$$

Since the constant c is arbitrary, it can be replaced by $\frac{c}{2}$. Hence, the general solution of the given differential equation can be written as:

$$x^2 + y^2 = c$$

Example 3 Find the general solution for the differential equation $x^2(2y+1)\frac{dy}{dx} - 1 = 0$

Solution: The given differential equation can be written as:

$$\frac{dy}{dx} = \frac{1}{x^2(2y+1)}$$

By separating variables, we have

$$(2y+1) dy = \frac{1}{x^2} dx$$

Integrating both sides we get:

$$\begin{aligned} \int (2y+1) dy &= \int \frac{1}{x^2} dx \\ \Rightarrow 2 \int y dy + \int dy &= \int x^{-2} dx \quad \Rightarrow y^2 + y = -\frac{1}{x} + C \end{aligned}$$

Hence, $y^2 + y + \frac{1}{x} = C$ represents the general solution for the given differential equation where C is an arbitrary constant.

4.2.2 Homogeneous Differential Equation

A first-order, first degree differential equation is called **Homogeneous** if it can be written in the form

$$\frac{dy}{dx} = F\left(\frac{y}{x}\right)$$

where $F\left(\frac{y}{x}\right)$ is a function of the ratio $\frac{y}{x}$ only. For example, $\frac{dy}{dx} = \frac{x^3 + xy^2}{y^3 - x^2y}$ is a

homogeneous differential equation because, it can be written as:

$$\frac{dy}{dx} = \frac{\frac{x^3 + xy^2}{x^3}}{\frac{y^3 - x^2y}{x^3}} = \frac{1 + \left(\frac{y}{x}\right)^2}{\left(\frac{y}{x}\right)^3 - \left(\frac{y}{x}\right)} = F\left(\frac{y}{x}\right)$$

On the other hand, the differential equation $\frac{dy}{dx} = x + y$ is not homogeneous because

$x + y$ cannot be expressed as a function of $\frac{y}{x}$.

Method to Solve a Homogeneous Differential Equation

The homogeneous differential equation:

$$\frac{dy}{dx} = F\left(\frac{y}{x}\right) \quad \dots(1)$$

can be converted into a separable differential equation in variables x and v by making the substitution:

$$y = vx \quad \dots(2)$$

Differentiating both sides of equation (2) w.r.t x :

$$\frac{dy}{dx} = v + x \frac{dv}{dx} \quad \dots(3)$$

Substituting the values of $\frac{y}{x}$ and $\frac{dy}{dx}$ from equations (2) and (3), the equation (1) can be written as:

$$v + x \frac{dv}{dx} = F(v)$$

Rewriting, we obtain:

$$x \frac{dv}{dx} = F(v) - v$$

It becomes separable differential equation.

$$\frac{1}{F(v) - v} dv = \frac{1}{x} dx$$

On integrating both sides:

$$\int \frac{1}{F(v) - v} dv = \int \frac{1}{x} dx$$

By solving integrals of the above equation and then substituting back $v = \frac{y}{x}$, we obtain the general solution for the homogeneous differential equation (1).

Note

If the equation $\frac{dy}{dx} = f(x, y)$ is homogeneous, then on substituting $y = vx$, $\frac{dy}{dx}$ is replaced by

$v + x \frac{dv}{dx}$ and $f(x, y)$ can easily be simplified by replacing x with 1 and y with v . For example, in

$\frac{dy}{dx} = \frac{x+y}{y-x}$, replacing x with 1 and y with v , in the right-hand side, we get $v + x \frac{dv}{dx} = \frac{1+v}{v-1}$.

Example 4 Find the general solution of the differential equation $\frac{dy}{dx} = \frac{x+y}{y-x}$.

Solution: The given differential equation is:

$$\frac{dy}{dx} = \frac{x+y}{y-x} \quad \dots(1)$$

Note that every term of the numerator and denominator in $f(x, y) = \frac{x+y}{y-x}$ is of degree

1. Thus, the differential equation (1) is homogeneous. On substituting $y = vx$, we have:

$$\begin{aligned} v + x \frac{dv}{dx} &= \frac{x+vx}{vx-x} = \frac{1+v}{v-1} &\Rightarrow x \frac{dv}{dx} &= \frac{1+v}{v-1} - v \\ x \frac{dv}{dx} &= \frac{-v^2+2v+1}{v-1} &\Rightarrow \frac{v-1}{-v^2+2v+1} dv &= \frac{1}{x} dx \end{aligned}$$

Integrating both sides we get:

$$\begin{aligned} \int \frac{v-1}{-v^2+2v+1} dv &= \int \frac{1}{x} dx \\ \Rightarrow -\frac{1}{2} \int \frac{-2v+2}{-v^2+2v+1} dv &= \ln|x| + \ln|c| &\Rightarrow -\frac{1}{2} \ln|-v^2+2v+1| &= \ln|cx| \\ \Rightarrow \ln|-v^2+2v+1| &= -2 \ln|cx| &\Rightarrow \ln|-v^2+2v+1| &= \ln|cx|^{-2} \\ \Rightarrow |-v^2+2v+1| &= \frac{1}{c^2 x^2} \end{aligned}$$

Substituting $v = \frac{y}{x}$ back in the above equation:

$$\begin{aligned} \left| -\frac{y^2}{x^2} + 2\frac{y}{x} + 1 \right| &= \frac{1}{c^2 x^2} &\Rightarrow \frac{|-y^2+2xy+x^2|}{x^2} &= \frac{1}{c^2 x^2} \\ \Rightarrow |-y^2+2xy+x^2| &= \frac{1}{c^2} &\Rightarrow -y^2+2xy+x^2 &= \pm \frac{1}{c^2} \end{aligned}$$

Renaming the arbitrary constant as $c \neq 0$, we get the required general solution of the given differential equation as follows:

$$-y^2 + 2xy + x^2 = c \text{ or } x^2 + 2xy - y^2 = c$$

Example 5 Solve the differential equation $x \sin\left(\frac{y}{x}\right) dy - \left[y \sin\left(\frac{y}{x}\right) - x \right] dx = 0$.

Solution: Rewrite the given differential equation as follows:

$$\frac{dy}{dx} = \frac{y \sin\left(\frac{y}{x}\right) - x}{x \sin\left(\frac{y}{x}\right)} = \frac{\frac{y}{x} \sin\left(\frac{y}{x}\right) - 1}{\sin\left(\frac{y}{x}\right)}$$

Note that the right-hand side of the above equation is a function of $\frac{y}{x}$ form only. Thus, it is a homogeneous differential equation. On substituting $y = vx$, we have:

$$v + x \frac{dv}{dx} = \frac{v \sin v - 1}{\sin v}$$

$$\Rightarrow x \frac{dv}{dx} = \frac{v \sin v - 1}{\sin v} - v = \frac{v \sin v - 1 - v \sin v}{\sin v} = -\frac{1}{\sin v}$$

$$\Rightarrow -\sin v \, dv = \frac{1}{x} \, dx$$

Integrating both sides:

$$\int (-\sin v) \, dv = \int \frac{1}{x} \, dx \Rightarrow \cos v = \ln|x| + \ln|c|$$

Replacing v by $\frac{y}{x}$ in the above equation, we get the general solution for the given differential equation as follows:

$$\cos\left(\frac{y}{x}\right) = \ln|cx|$$

EXERCISE 4.2

1. Which of the following differential equations are separable and which of them are homogeneous?

(i) $x \frac{dy}{dx} = 1 + y$

(ii) $x^2(2y+1)dy - dx = 0$

(iii) $(2xy + x^2)dy - y^2dx = 0$

(iv) $\frac{dy}{dx} = e^{x-y}$

(v) $\frac{dT}{dt} + k(T - T_m) = 0$

(vi) $\frac{dy}{dx} = \ln(x) - \ln(y); x > 0, y > 0$

Find the general solutions of the differential equations given in problems (2 to 21):

$$2. \quad \frac{dy}{dx} = \left(\frac{1-y^2}{1-x^2} \right)^{\frac{1}{2}} \quad 3. \quad \frac{dy}{dx} = e^{x-y} \quad 4. \quad \frac{dy}{dx} = \sqrt{y} \cos^2 \sqrt{y}$$

$$5. \quad \sqrt{x} \frac{dy}{dx} = e^{y+\sqrt{x}} \quad 6. \quad \frac{dy}{dx} = 2x\sqrt{1-y^2} \quad 7.$$

$$\frac{dy}{dx} = \frac{1+x}{(1-x)(1+x^2)}$$

$$8. \quad x^2 dx + (1-x^2)dy = 0 \quad 9. \quad y - x \frac{dy}{dx} = 2 \left(y^2 + \frac{dy}{dx} \right)$$

$$10. \quad \sec^2 x \tan y dx + \sec^2 y \tan x dy = 0 \quad 11. \quad (e^{2x} + e^{-2x}) dy + (e^{-2x} - e^{2x}) dx = 0$$

$$12. \quad x \sin x dx + \ln y dy = 0 \quad 13. \quad \frac{dy}{dx} = \cos^2 \left(\frac{y}{x} \right) + \frac{y}{x}$$

$$14. \quad (y^2 + 2xy) dx + x^2 dy = 0 \quad 15. \quad (x^2 + 3y^2) dx^2 - 2xy dy = 0$$

$$16. \quad (x^2 + xy + y^2) dx - x^2 dy = 0 \quad 17. \quad x \frac{dy}{dx} = x e^{-\frac{y}{x}} + y$$

$$18. \quad x \frac{dy}{dx} - y = \frac{x^4 + x^3 y}{y^3 - x^3} \quad 19. \quad y - x \frac{dy}{dx} = 3 \left(1 + x \frac{dy}{dx} \right)$$

$$20. \quad y dx + x dy = 0 \quad 21. \quad \frac{dy}{dx} + \frac{2xy}{2y+1} = x$$

Solve the initial value problems (22 to 25):

$$22. \quad \frac{dy}{dx} - x = xy^2; \quad y(0) = 1 \quad 23. \quad \frac{ds}{dt} + 2st = 0; \quad s = 4e \text{ when } t = 0$$

$$24. \quad \left(y + \sqrt{x^2 + y^2} \right) dy - x dy = 0; \quad y = 0 \text{ when } x = 0 \quad 25. \quad \frac{dy}{dx} = \frac{x+y}{x}; \quad y(1) = 1$$

4.3 Applications of First Order Differential Equations in Real-Life Problems

First-order differential equations play a vital role in modeling various real-life phenomena in fields such as physics, biology, chemistry, economics, and engineering. These equations involve the rate of change of a quantity and help describe how that quantity evolves over time.

Example 6 (Population Growth)

In a culture, there are 100 bacteria initially and are doubled in 2 hours. Find the number of bacteria 7 hours later.

Solution: Let N represent the number of bacteria at time t , then we have to find $N(7)$ using the information:

$$N(0) = 100$$

$$N(2) = 200$$

We have to solve the differential equation:

$$\frac{dN}{dt} = kN$$

Where $k > 0$, because the population is increasing. Note that the above differential equation is separable. It can be written as follows:

$$\frac{1}{N} dN = k dt$$

On integrating both sides:

$$\int \frac{1}{N} dN = \int k dt$$

$$\Rightarrow \ln|N| = kt + C \quad \dots(1)$$

Using the condition $N(0) = 100$ in equation (1), we get $C = \ln(100)$.

Now, equation (1) becomes:

$$\ln|N| = kt + \ln(100) \quad \text{or} \quad \ln\left|\frac{N}{100}\right| = kt$$

$$\Rightarrow \frac{N}{100} = e^{kt}$$

$$\Rightarrow N = 100e^{kt} \quad \dots(2)$$

Applying the condition $N(2) = 200$, we get:

$$200 = 100e^{2k} \quad \text{or} \quad e^{2k} = 2. \text{ which gives } 2k = \ln 2 \quad \text{or} \quad k = \frac{1}{2} \ln 2 = \ln \sqrt{2}$$

Thus, equation (2) is rewritten as:

$$N = 100e^{(\ln \sqrt{2})t}$$

Substituting $t = 7$ in the above equation, we get:

$$N(7) = 100e^{7 \ln \sqrt{2}} = 100e^{\ln(2)^{\frac{7}{2}}} = 100(2)^{\frac{7}{2}} \approx 1131.371$$

Hence, the number of bacteria 7 hours later is 1131 (approximately).

Example 7 (Radioactive Decay)

A certain radioactive substance has a mass of 80 grams initially. After 10 hours, only 50 grams remain.

- Find decay constant.
- How much of the substance will remain after 24 hours?
- After how many hours will only 20 grams remain?

Solution: Let M represents the mass of radioactive decay at time t . Then we have, $M(0) = 80$ and $M(10) = 50$. The differential equation for the radioactive decay is given by:

$$\frac{dM}{dt} = -kM$$

Which is clearly a separable differential equation. On separating the variables and then integrating both sides, we get:

$$M(t) = ce^{-kt} \quad \dots(1)$$

Where c is the constant of integration and $k > 0$ is the constant of proportionality (decay constant).

(a) Applying initial condition $M(0) = 80$ on equation (1), we get $c = 80$.

Now, imposing the condition $M(10) = 50$ on equation (1), we get $50 = 80e^{-10k}$ which gives:

$$k = -\frac{1}{10} \ln\left(\frac{5}{8}\right) \approx 0.047.$$

Hence the decay constant is 0.047 approximately.

(b) Substituting the values of c and k in equation (1), we get:

$$M(t) = 80e^{-0.047t} \quad \dots(2)$$

$$\Rightarrow M(24) = 80e^{-0.047(24)} \approx 25.8944 \approx 26 \text{ grams}$$

Hence, there will be approximately 26 grams substance after 24 hours.

(c) Substituting $M(t) = 20$ in equation (2), we get $20 = 80e^{-0.047t}$. Solving this equation for t , we have $t \approx 29.496$. Hence, 20 grams substance will be left after approximately 29.5 hours.

Example 8 (Deflation Problem in Economics)

Suppose an economy is experiencing deflation at 4% per year. If the current price of an item is Rs. 500, find its expected price after 3 years.

Solution: Let P denote the price of item at time t . Since there is a deflation, the differential equation concerning the problem is given by:

$$\frac{dp}{dt} = -(4\%)P = -0.04P$$

On solving the above differential equation, we get:

$$P(t) = C e^{-0.04t} \quad \dots(1)$$

Since the current price of item is Rs. 500, we have initial condition $P(0) = 500$. Using this condition in equation (1), we get:

$$P(t) = 500 e^{-0.04t}$$

Substituting $t = 3$ in the above equation:

$$P(3) = 500 e^{-0.04(3)} \approx 443.46$$

Hence the expected price of the item after three years will be Rs. 443.5.

Example 9 (Cooling/Heating Problem)

A cup of coffee is served at 90°C in a room where the temperature is 25°C . After 10 minutes, the coffee cools to 60°C . Find the temperature of the coffee after 20 minutes.

Solution: Let T denote the temperature of the coffee at time t . Using the conditions $T(0) = 90$ and $T(10) = 60$, we have to calculate $T(20)$ by solving the differential equation:

$$\frac{dT}{dt} = -k(T - 25)$$

Note that the above differential equation is separable and can be rewritten as:

$$\frac{1}{(T - 25)} dT = -k dt$$

On integrating, we have:

$$\begin{aligned} \int \frac{1}{(T - 25)} dT &= -k \int dt \Rightarrow \ln|T - 25| = -kt + \ln|c| \\ \Rightarrow \ln \left| \frac{T - 25}{c} \right| &= -kt \Rightarrow \frac{T - 25}{c} = e^{-kt} \\ \Rightarrow T(t) &= 25 + ce^{-kt} \quad \dots(1) \end{aligned}$$

Applying initial condition $T(0) = 90$ on above equation, we get $90 = 25 + c$ or $c = 65$. For the second condition $T(10) = 60$, we get $60 = 25 + 65e^{-10k}$ from equation (1). On solving this equation for k , we have: $e^{10k} = \frac{13}{7}$ or $k \approx 0.0619$. Now, the equation (1)

can be written as:

$$T(t) = 25 + 65 e^{-0.0619t}$$

Substituting, $t = 20$ in the above equation:

$$T(20) = 25 + 65 e^{-0.0619(20)} \Rightarrow T(20) \approx 43.85$$

Hence the approximate temperature of the coffee after 20 minutes will be 43.85°C .

Example 10 (RL Circuit Problem)

An RL circuit has an emf of 5 volts, a resistance 50 ohms, an inductor of 1 henry and no initial current. Find the current in the circuit at any time t .

Solution: We have to find the current I flowing in the circuit at time t using the information:

$$V_s = 5 \text{ volts}, R = 50 \Omega, \text{ and } I(0) = 0.$$

The differential equation governing the RL circuit at time t is given by: (see Example 4, Section 4.1.2)

$$L \frac{dI}{dt} = V_s - RI \quad \because L = 1 \text{ henry}$$

Substituting the given values:

$$\frac{dI}{dt} = 5 - 50I$$

The above differential equation is separable. On separating the variables and integrating, we have:

$$\begin{aligned} \frac{1}{5} \int \frac{1}{1-10I} dI &= \int dt \quad \Rightarrow \quad -\frac{1}{50} \int \frac{-10}{1-10I} dI = \int dt \\ \Rightarrow \quad -\frac{1}{50} \ln|1-10I| &= t + C \quad \dots(1) \end{aligned}$$

Applying the initial condition $I(0) = 0$:

$$\begin{aligned} -\frac{1}{50} \ln|1-10(0)| &= 0 + C \\ \Rightarrow \quad -\frac{1}{50} \ln|1| &= C \quad \Rightarrow \quad C = 0 \end{aligned}$$

For $C = 0$, the equation (1) becomes:

$$\begin{aligned} -\frac{1}{50} \ln|1-10I| = t &\Rightarrow \ln|1-10I| = -50t \quad \Rightarrow \quad |1-10I| = e^{-50t} \\ &\Rightarrow \quad \pm(1-10I) = e^{-50t} \end{aligned}$$

On checking the initial condition $I(0) = 0$ for the above equation we have, $\pm(1-10(0)) = e^{-50(0)}$ or $\pm 1 = 1$. This means that the negative sign is to be ignored.

Thus, we have:

$$\begin{aligned} 1-10I &= e^{-50t} \\ \Rightarrow \quad I(t) &= \frac{1}{10} (1 - e^{-50t}) \end{aligned}$$

EXERCISE 4.3

- A particle is moving in a straight line and its acceleration is given by $a = 2t - 7$. Find
 - velocity v in terms of t if $v = 10$ m/sec, when $t = 0$.
 - distance s in terms of t if $s = 0$ m/sec, when $t = 0$.
- In a culture, there were 1000 bacteria initially and were found to be 900 after five hours. Use differential equation to find the number of bacteria 7 hours later.
- The number of bacteria in a culture currently is 1000. Three hours ago, it was 750. What was the number of bacteria five hours ago?
- A radioactive isotope has a half-life of 12 hours. The initial mass is 160 grams.
 - What is the decay constant?
 - How much mass will remain after 36 hours?
 - After how many hours will only 10 grams remain?
- Suppose the inflation rate for the cost of a basket of goods is 8% per year. If the current price level is Rs. 1000, use differential equation to find the price level after 5 years.
- Use a differential equation to find the current price of a good if the deflation rate is 11% per year and its price after ten years is expected to be Rs. 5000.
- Aslam deposited Rs. 5000 on opening an account in a bank 15 years ago. Using differential equation, find the constant annual rate of growth if he closes his account now by receiving Rs. 15,000.
- A can of soda at 4°C is placed in a room at 24°C . After 30 minutes, its temperature is 12°C . Find the temperature after 1 hour.
- A fully insulated battery overheats during operation and reaches 80°C . After shutdown, it begins to cool without any external influence. If it cools to 50°C in 2 hours, how long will it take to cool to 15°C ?
- An RL circuit has a battery of 12 volts, a resistor of 60 Ohms, and an inductor of 2 Henries. If the circuit is closed at time $t = 0$ with initial current zero, find the current $I(t)$ flowing in the circuit at any time t .
- An RC circuit has an emf of 12 volts, resistance $R = 6\Omega$ and capacitance $C = 3$ farad. Initially, the capacitor is uncharged. Find the current $I(t)$ at any time t .

Half-Life

Half-life is the time required for a quantity of a radioactive substance to reduce to half of its initial amount due to radioactive decay.