

CHAPTER 16

ELECTRICITY

Student's learning outcomes (SLOs)

After studying this chapter, students will be able to:

- define and calculate electric current, using the equation; $I = Q/t$.
- explain electrical conduction in metals in terms of the movement of free electrons.
- state that current is measured in amperes and that one ampere is equal to one coulomb per second ($C s^{-1}$).
- differentiate between direct current D.C and alternating current A.C.
- differentiate between conventional and electronic current.
- justify and illustrate the use of ammeters (analog and digital) with different ranges.
- define e.m.f. as the electrical work done by a source in moving a unit charge around a complete circuit, using the equation; $E = W/Q$.
- define potential difference (p.d.) as the work done by a unit charge passing through a component, using the equation; $V = W/Q$.
- state that e.m.f. and p.d. are measured in volts and that one volt is equal to one joule per coulomb ($J C^{-1}$).
- illustrate the use of voltmeters (analog and digital) with different ranges.
- calculate the total e.m.f. when multiple sources are arranged in series.
- state that the e.m.f. of identical sources connected in parallel is equal to the e.m.f. of one of the sources.
- define and calculate resistivity, explaining its direct proportionality to resistance and length, and inverse proportionality to cross-sectional area.

- define and apply Ohm's law using the equation; $R = V/I$.
- describe the effect of temperature increase on the resistance of a resistor, such as in a filament lamp.
- draw circuit diagrams using components such as cells, batteries, power supplies, generators, switches, resistors, thermistors (NTC), light-dependent resistors (LDRs), lamps, motors, ammeters, voltmeters, transformers, fuses, relays, diodes, and LEDs.
- calculate the combined resistance of resistors in series.
- calculate the combined resistance of resistors in parallel.
- calculate current, voltage, and resistance in parts of a circuit or the whole circuit.
- describe the action of negative temperature coefficient (NTC) thermistors and light-dependent resistors (LDRs) and their use as input sensors.
- analyze the function of variable potential dividers in circuits, using the equation; $R_1/R_2 = V_1/V_2$.
- justify and illustrate the use of colour codes for resistors.
- use the equation; power = current \times voltage ($P = IV$) to solve simple problems.
- use the equation energy = current \times voltage \times time ($E = IVt$) to solve simple problems.
- define the kilowatt-hour (kWh).
- explain the need to choose components with suitable power ratings.
- calculate the cost of using electrical appliances where the energy unit is the kWh.
- explain the use and operation of trip switches and fuses and choose appropriate fuse ratings and trip switch settings.
- explain what happens when a live wire touches a metal case that is earthed.
- explain why the outer casing of an electrical appliance must be either non-conducting (double-insulated) or earthed.
- state that a mains circuit consists of a live wire (line wire), a neutral wire, and an earth wire.
- explain why fuses and circuit breakers are connected into the live wire for the circuit to be switched OFF safely.
- explain why domestic supplies are connected in parallel.

Electricity is a branch of physics which deals with the flow of charges. The movement of charges results in the flow of electric current which plays an important role in our daily lives. The electricity illuminates our homes, fuels our industries, and connects us across vast distances. In this chapter, we will learn the basic concepts of electricity, including electric current, potential difference, Ohm's law, electrical resistivity, and common uses of electricity, benefits and its hazards. These contents will help in building up basic knowledge about electricity.

16.1 Electric Current

In an atom, the electrons and positively charged nucleus are held together by strong force. However, in metals some electrons can move freely as these are not tightly bonded with the nucleus. These electrons move randomly within a metallic conductor. However, when an external electric field is applied, these electrons move in a specific direction (Fig. 16.1). This flow of charges is called an electric current. The electric current can be caused due to movement of both positive and negative charges.

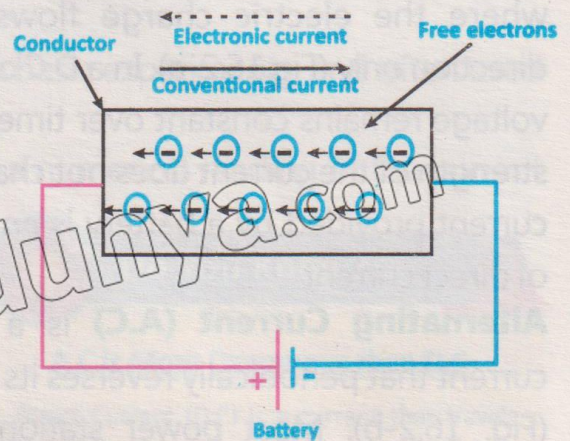

Fig. 16.1: Flow of electrons in a circuit

Amount of charge passing through any cross section of a conductor per unit time is called electric current.

If Q charge flows in time t , then current I can be expressed as:

$$I = \frac{Q}{t} \dots\dots\dots (16.1)$$

The SI unit of electric current is ampere (A). One ampere is defined as the flow of one coulomb of electric charge per second, which can be written as; $1 \text{ A} = 1 \text{ C s}^{-1}$.

Before the discovery of electrons, the electric current was considered to be due to flow of positive charges, named as Conventional Current. These charges move from positive terminal to the negative terminal of the power source. Later, after the discovery of electrons, the electric current was described due to the movement of electrons which was named

Do You Know?

Solution of electrolyte

In electrolysis, current is produced due to flow of both positive and negative ions. In the electrolyte, negative ions are attracted to the anode. This movement of ions within the electrolyte constitutes an electric current within the internal circuit.

as electronic current. The movement of electrons in one direction corresponds to the movement of positive charges in opposite direction. Despite this difference, both concepts are used in practice, with conventional current being the standard in circuit analysis.

Types of Electric Current

1. Direct Current (DC)
2. Alternating Current (AC)

Direct Current (D.C) is an electrical current where the electric charge flows in one direction only (Fig.16.2-a). In a D.C circuit, the voltage remains constant over time, and the strength of the current does not change. The current provided by a battery is an example of direct current.

Alternating Current (A.C) is a type of current that periodically reverses its direction (Fig. 16.2-b). Most power stations in our country produce alternating current. A.C changes direction every $1/50$ second, and its frequency is 50 hertz (Hz). One advantage of A.C over D.C is that it can be transmitted over long distances with low power loss.

Ammeter

An ammeter is a device used to measure the current flowing through a circuit. It must be connected in series with the component whose current is to be measured. There are two main types of ammeters: analog ammeters and digital ammeters. Both types are available in different current ranges to measure both small and large currents. In Fig. 16.3, we can see the digital ammeter (left) and analog ammeter (right) side by side, illustrating the difference in display type and range options. Both types are connected in series with the load to measure current, but the display method and

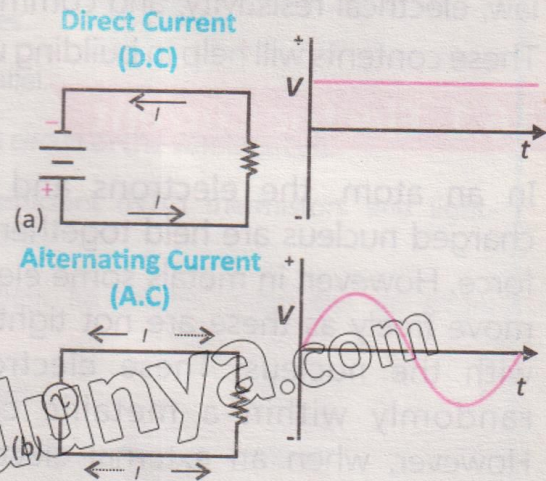

Fig. 16.2: Types of current (a) D.C (b) A.C

Tidbit

In any circuit, electric current prefers the path of least resistance, just like water flowing downhill.



Fig. 16.3: Comparison of digital and analog ammeters

ease of reading differ significantly.

Types of Ammeters

Analog Ammeter: An analog ammeter uses a needle and scale to indicate the current. The current flowing through the circuit generates a magnetic field that moves the needle on the scale. The scale usually has multiple ranges, and the correct range must be selected depending on the expected current. Analog ammeters typically have multiple selectable ranges, such as 0–10 mA, 0–100 mA, etc. The correct range must be selected to avoid damage to the device and to ensure accurate readings.

Use: Ideal for visual indication of current flow in basic experiments, and often used in educational settings due to its simplicity.

Digital Ammeter: A digital ammeter provides a numerical reading of the current on a digital display. It offers more precision compared to an analog ammeter. Digital ammeters also come with various ranges, and some automatically adjust the range depending on the detected current. They are typically more accurate and easier to read than analog meters. Digital ammeters are widely used in scientific, industrial, and electrical applications where precise measurements are critical.

Range Selection

Ammeters are equipped with multiple ranges to accommodate different magnitudes of current. Selecting the correct range is important to ensure that ammeter is not damaged and to provide an accurate measurement. Low-range ammeters (e.g. 0–1 A) are used to measure small currents, typically in laboratory experiments.

High-range ammeters (e.g. 0–10 A) are used to measure larger currents, such as those in power systems or industrial circuits.

16.2 Electromotive Force and Potential Difference

Electromotive force (e.m.f.) and potential difference (p.d.) are two important concepts, both measured in volts (V). One volt is defined as one joule of energy per coulomb of charge ($1 \text{ V} = 1 \text{ J C}^{-1}$). This means that if 1 joule of energy is used to



Do You Know?

A.C is More Dangerous than D.C

Direct Current (D.C) is a current that travels from negative to the positive terminal. It does not change its direction. It is the current, we can get from a battery. It can cause burning if the positive and negative wires can come into contact.

move 1 coulomb of charge, the voltage is 1 volt.

Electromotive Force (e.m.f.)

A source of electromotive force (e.m.f.) converts non-electrical energy, like chemical, thermal, or mechanical energy, into electrical energy. Examples of such sources include batteries (which convert chemical energy), thermocouples (which convert thermal energy), and generators (which convert mechanical energy). When a conductor is connected to a battery, current flows due to the potential difference between the battery's terminals. The battery provides energy to move positive charges from the positive terminal through the conductor to the negative terminal (Fig. 16.4). Once the charge reaches the negative terminal (lower potential), the battery does work to push it back to the positive terminal (higher potential). This cycle keeps the current flowing continuously. In short, the e.m.f. supplies the energy needed to keep the charges in motion.

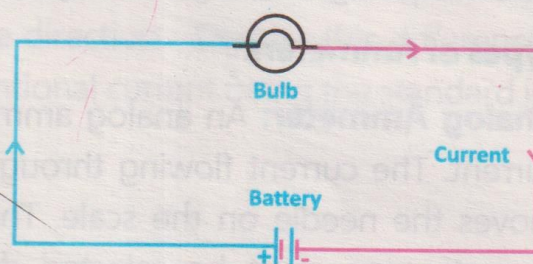

Fig. 16.4: Electromotive force

Electromotive force is the electric potential energy supplied by a battery to a unit positive charge when it flows through the closed circuit.

Mathematically:

$$\text{e.m.f} = \frac{\text{Energy}}{\text{Charge}} \dots\dots\dots (16.2)$$

$$\text{or } E = \frac{W}{Q} \dots\dots\dots (16.3)$$

E is the e.m.f., W is energy converted from non-electrical forms to electrical form and Q is the charge. Emf of a battery can be measured directly by connecting its terminal to a voltmeter as shown in Fig. 16.5.

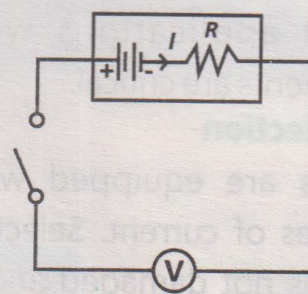

Fig. 16.5: Schematic diagram for measuring e.m.f. of the battery

Potential Difference

A battery converts chemical energy into electrical energy. Inside the battery, a chemical reaction causes a buildup of electrons at the negative terminal and a shortage of electrons at the positive terminal. This imbalance creates a potential difference between the terminals, which allows electrons to flow through a connected circuit, generating an electric current. The battery continues to drive this

flow as long as the chemical reaction is active, providing a steady supply of energy. In short, the chemical action inside the battery creates a potential difference that allows the current in the circuit.

Electric potential (V) is the amount of electric potential energy (W) per unit charge (Q) at a specific point in an electric field.

i.e; $V = \frac{W}{Q}$ (16.4)

The potential difference is the difference in the values of electric potential between two points in the electric field (Fig. 16.6). The unit of electric potential is volt (V). One volt equals to one joule per coulomb ($V = J C^{-1}$). Potential difference is also called voltage which is the energy used by a component in the circuit. Voltage can also be referred to e.m.f. which is the energy supplied by a source like a battery. Both potential difference and e.m.f. are measured in volts.

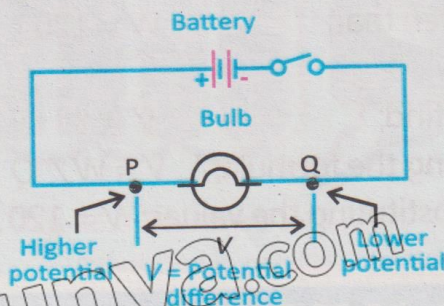

Fig. 16.6: Potential difference across two points in a circuit

Voltmeter

Voltage can be measured using a device called voltmeter. Voltmeter can also be of analog and digital types. Both types are available with different ranges, allowing them to measure voltages of varying magnitudes. Analog voltmeters use a needle and a scale to display the voltage, making them useful for observing changes or trends over time. Digital voltmeters, on the other hand, show the voltage as a numerical value on a screen, offering greater precision and ease of reading. For example, a low-range voltmeter might measure millivolts (mV),

Do You Know?

EMF

VOLTAGE

The electromotive force is the type of energy which forces a unit positive charge to move from the positive to the negative terminal of the source. It separates the two charges from each other.

Voltage is the difference in electric potential between two points. The voltage between two points is equal to the work done per unit of charge against a static electric field to move a test charge between two points.

Analog voltmeter

Digital voltmeter

Fig. 16.7: Types of voltmeters

while a high-range voltmeter could measure hundreds or even thousands of volts. Choosing the right range is important, using a low-range voltmeter for a high voltage could damage the device, while using a high-range voltmeter for a small voltage, might not provide accurate readings. Analog and digital voltmeters are shown in Fig. 16.7.

Example 16.1: A battery does 120 J of work to move a charge of 20 C through a circuit. What is the potential difference across the circuit?

Solution:

Given that; $W = 120 \text{ J}, Q = 20 \text{ C}$

To find; $V = ?$

Using the formula; $V = W / Q$

Substituting the values; $V = 120 \text{ J} / 20 \text{ C} = 6 \text{ V}$

Total E.M.F. of Series Connected Sources

When multiple voltage sources (e.g., batteries) are connected in series (Fig. 16.8), their total electromotive force (e.m.f.) is simply the sum of their individual e.m.f. This is because the voltage sources add energy to the charges one after the other.

Formula:

$$E_{\text{total}} = E_1 + E_2 + \dots + E_n$$

where

E_{total} = total e.m.f.

E_1, E_2, \dots, E_n = e.m.f. of the individual sources

Example: If four batteries, each with an e.m.f. of 1.5 V (Fig. 16.8), are connected in series, the total e.m.f. would be 6 V.

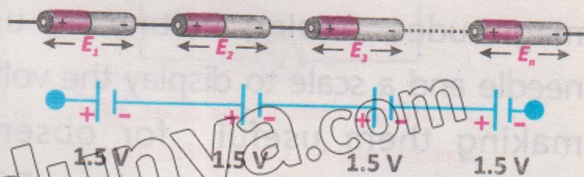

Fig. 16.8: Series combination of batteries

E.M.F. of Identical Sources Connected In Parallel

When multiple identical sources (such as batteries with the same voltage) are connected in parallel (Fig. 16.9), the total e.m.f. across all of them remains equal to the e.m.f. of a single source. This is because, in parallel connections, each

battery is connected directly across the same two points, meaning the voltage (e.m.f.) does not change. However, the total current supplied by the sources will increase due to the additional paths available for current to flow.

Explanation: In a parallel connection, each source contributes current independently while maintaining the same voltage across each of them. This results in the total e.m.f. remaining equal to the e.m.f. of one of the individual sources, but the total current becomes the sum of the individual currents provided by each source.

Formula: For identical sources in parallel:

$$E_{total} = E_1 = E_2 = \dots = E_n$$

where

E_{total} is the total e.m.f. across the parallel sources.

E_1, E_2, \dots, E_n are the e.m.f.'s of the individual sources (which are identical for each source in the parallel connection).

Example: In Fig. 16.9, four 1.5 V batteries are connected in parallel. The total e.m.f. across the combination will still be 1.5 V, just as it is for a single battery.

For Your Information

In a series combination, the total e.m.f. increases, making it easier to push electric charges through the circuit. However, the total current depends on the overall resistance in the circuit.

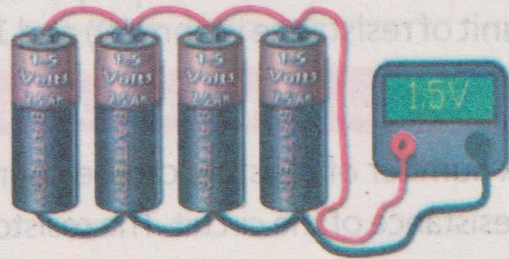

Fig. 16.9: Four 1.5 V batteries connected in parallel

Brain Teaser

Three identical 5 V cells are connected in parallel. What is the total e.m.f. of the combination?

16.3 Ohm's Law

In 1826, George Simon Ohm made an investigation of the relationship between electric potential difference across a conductor and the current flowing through it. The current in a conductor was increased by increasing the potential difference across its ends. According to Ohm's law;

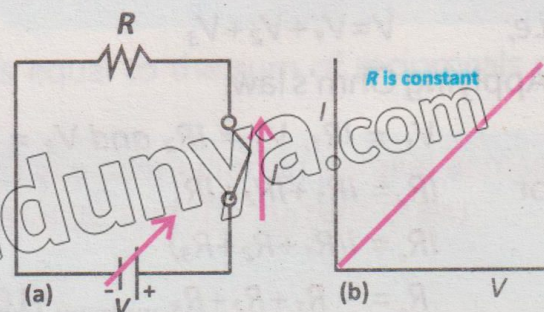

Fig.16.10: (a) Ohm's law circuit (b) I-V graph for ohmic conductor

The current flowing through a conductor is directly proportional to the potential difference V across its two ends of a conductor, provided the physical state (dimension, temperature, etc.) of the conductor remains same.

Mathematically;

$$I \propto V$$
$$I = \frac{1}{R} V$$

$$V = IR \quad \dots\dots\dots (16.5)$$

where R is constant of proportionality called resistance of a conductor. The SI unit of resistance is ohm (Ω) and $1 \Omega = V A^{-1}$.

16.4 Combination of Resistances

A number of resistors can be connected in a circuit to increase or decrease the net resistance of the circuit. The resistors are connected either in series or in parallel and the equivalent resistance of the circuit depends upon the type of combination.

Series Combination of Resistors

When resistors are connected in such a way that there is only one path for the current to flow, then it is called series combination of resistors. For example, consider three resistors R_1 , R_2 and R_3 connected in series as shown in Fig. 16.11. When this combination is connected to a battery of V volts, it draws current I from the battery. Let R_e be a single resistor representing the total resistance of the circuit, also called equivalent resistance.

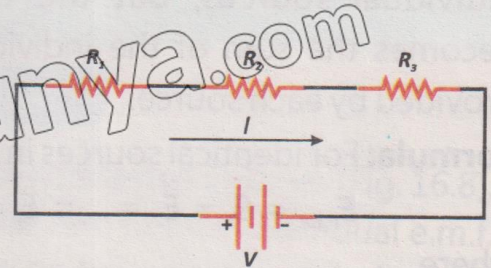

Fig.16.11: Resistors in series

The total voltage in the circuit will be the sum of voltage across the three resistors.

i.e; $V = V_1 + V_2 + V_3$

Applying Ohm's law:

$$V_1 = IR_1, V_2 = IR_2 \text{ and } V_3 = IR_3$$

or $IR_e = IR_1 + IR_2 + IR_3$

$$IR_e = I(R_1 + R_2 + R_3)$$

$$R_e = R_1 + R_2 + R_3 \quad \dots\dots\dots (16.6)$$

Thus, equivalent resistance is equal to the sum of individual resistances.

Parallel Combination of Resistors

When there are multiple paths for current flow in a circuit (as indicated in the diagram), the combination of resistances is referred to as parallel combination. The electric potential across each resistance is the same and equal to the applied potential. Each resistor has a steady current flowing through it. Consider three resistors R_1 , R_2 and R_3 connected in parallel (Fig. 16.12). When these are connected to a battery of V volts, it draws a current I from the battery. R_e is a single resistor. This resistor is such that when it is connected to the same battery of V volts, it also draws current I from the battery. This resistor is therefore called equivalent resistor and its resistance is called equivalent resistance. The total current in the circuit will be the sum of currents flowing through the resistors;

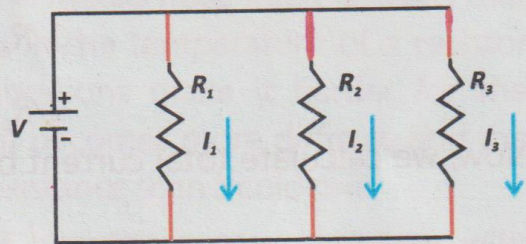

Fig.16.12: Resistors in parallel

$$I = I_1 + I_2 + I_3$$

Applying Ohm's law:

$$V = I_1 R_1, \quad V = I_2 R_2, \quad V = I_3 R_3$$

or
$$I_1 = \frac{V}{R_1}, \quad I_2 = \frac{V}{R_2}, \quad I_3 = \frac{V}{R_3}$$

or
$$\frac{V}{R_e} = \frac{V}{R_1} + \frac{V}{R_2} + \frac{V}{R_3}$$

or
$$\frac{V}{R_e} = V \left[\frac{1}{R_1} + \frac{1}{R_2} + \frac{1}{R_3} \right]$$

$$\frac{1}{R_e} = \frac{1}{R_1} + \frac{1}{R_2} + \frac{1}{R_3} \quad \dots\dots\dots (16.7)$$

Tip:
Birds are safe because both their feet touch the same potential wire. There is no voltage difference, so no current flows through their bodies.

Thus, the reciprocal of equivalent resistance is equal to the sum of reciprocals of individual resistances.

Example 16.2: Two resistors of 8Ω and 24Ω are connected in parallel across a 30 V power supply. Calculate the total resistance and the current drawn from the power supply.

Solution:

Given that; $R_1 = 8 \Omega$, $R_2 = 24 \Omega$ and $V = 30 \text{ V}$

To find; $R_e = ?$ and $I = ?$

Using the formula for parallel resistance: $1/R_e = 1/R_1 + 1/R_2$

Substituting the values; $1/R_e = (1/8) + (1/24)$

$$1/R_e = (3/24) + (1/24)$$

$$1/R_e = 4/24 \text{ or } R_e = 24/4 = 6 \Omega$$

Now, we calculate total current by using Ohm's Law:

$$I = V/R_e = 30 \text{ V} / 6 \Omega = 5 \text{ A}$$

16.5 Electrical Resistivity

The opposition to the flow of electric current is called resistance.

This resistance is directly proportional to the length of the conductor and inversely proportional to its area. If A is the area and R is the resistance of a conductor (Fig. 16.13), then mathematically we can write it as:

$$R \propto L \text{ or } R \propto \frac{L}{A}$$

$$R = \rho \frac{L}{A}$$

$$R = \rho \frac{L}{A} \dots\dots (16.8)$$

Here, ρ is a constant called electrical resistivity of a material which quantifies how strongly a material resists to electric current. Materials with high resistivity are poor conductors of electricity, while those with low resistivity are good conductors. The SI unit of resistivity is the ohm-metre ($\Omega \text{ m}$).

Resistance of a cubic metre of a material is called resistivity.

Effect of Temperature on Resistance of a Conductor

The resistance and the resistivity of a conductor can change with temperature. In most conductors such as metals, the electrical resistance increases with temperature because atomic vibrations resist electron flow.

For example, in a filament lamp, when the

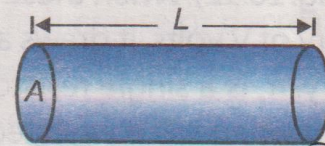

Fig.16.13: Resistivity of a material

Table 16.1: Electrical resistivity of different materials

Material	Electrical resistivity ($10^{-8} \Omega \text{ m}$)
Silver	1.7
Copper	1.69
Aluminium	2.75
Tungsten	5.25
Platinum	10.6
Iron	9.8
Nichrome	100
Graphite	3500

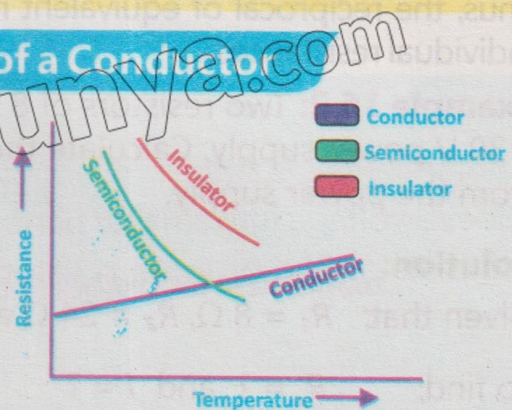

Fig.16.14: Temperature effect on materials

temperature of the filament (resistor) increases, its resistance also increases. This occurs because the filament is made of metal, and metals have free electrons that causes the flow of electric current. The increase in the temperature of a resistor increases the vibration of its atoms. These vibrations make it harder for the electrons to move. As a result, the flow of current becomes more difficult, and the resistance goes up. So, a hot filament has more resistance than a cold one.

In the case of semiconductors and insulators, resistance may decrease with temperature due to increase in the mobility of free charge carriers. For example, thermistor, which is made up of a semiconductor material, is a type of resistor whose resistance decreases as its temperature increases. At low temperatures, the semiconductor material has fewer free charge carriers (electrons or holes), resulting in high resistance. As the temperature rises, more charge carriers are released, increasing conductivity and reducing resistance. Due to change in resistance, the resistivity also changes accordingly. The effect of temperature on resistance of different materials is graphically shown in Fig. 16.14.

Example 16.3: An aluminium wire has a length of 15 m, a cross-sectional area of $3 \times 10^{-6} \text{ m}^2$, and a resistivity of $2.82 \times 10^{-8} \Omega \text{ m}$. Calculate its resistance.

Solution:

Given that; Resistivity $\rho = 2.82 \times 10^{-8} \Omega \text{ m}$

Length $L = 15 \text{ m}$, $A = 3 \times 10^{-6} \text{ m}^2$

To find; Resistance $R = ?$

Using the formula: $R = \rho (L / A)$

Substituting the values

$$R = (2.82 \times 10^{-8} \Omega \text{ m}) \times (15 \text{ m} / 3 \times 10^{-6} \text{ m}^2)$$

$$R = (2.82 \times 10^{-8}) \times (5 \times 10^6)$$

$$R = 0.141 \Omega$$

The resistance of the wire is 0.141 Ω .

16.6 Potential Divider Circuit

A potential or voltage divider is a circuit that divides a voltage into smaller parts using resistors. It consists of two or more resistors connected in series across a voltage source (Fig. 16.15). The voltage across each resistor is proportional to its resistance relative to the total resistance of the circuit.

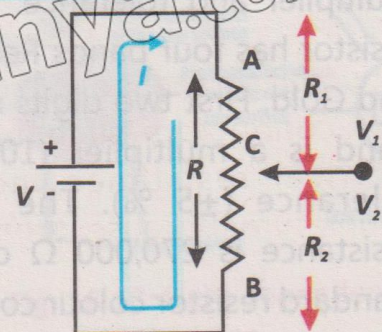

Fig.16.15: Potential divider circuit

Consider two resistors R_1 and R_2 connected in series. The voltage across each resistor is given by

$$\frac{R_1}{R_2} = \frac{V_1}{V_2} \dots\dots\dots (16.9)$$

where $V_1 =$ voltage across R_1
and $V_2 =$ voltage across R_2

The total voltage (V_{total}) is the sum of V_1 and V_2 :

$$V_{total} = V_1 + V_2 \dots\dots\dots (16.10)$$

The voltage across each resistor can also be calculated using the formulae:

$$V_1 = IR_1 = \frac{V_{total}}{R_e} \times R_1$$

$$V_1 = V_{total} \times \frac{R_1}{R_1 + R_2} \dots\dots\dots (16.11)$$

Similarly

$$V_2 = V_{total} \times \frac{R_2}{R_1 + R_2} \dots\dots\dots (16.12)$$

16.7 Resistor Colour Codes

The resistor colour codes is a system of coloured bands printed on resistors to indicate their resistance value and tolerance (Fig.16.16). Tolerance means how much a resistor's real value can be different from the value written on it. In this way, resistor's values can be identified without using multimeter. Each colour represents a specific digit and multiplier. In a four band resistor, the first and second bands indicate 1st and 2nd digit, the 3rd and 4th bands show multiplier and tolerance. For example, a resistor has four bands Red, Violet, Yellow and Gold. First two digits show 27, Yellow band is a multiplier (10^4), gold shows tolerance ($\pm 5\%$). The final value of resistance is 270,000 Ω or 270 k Ω . The standard resistor colour codes are given in Table 16.2.

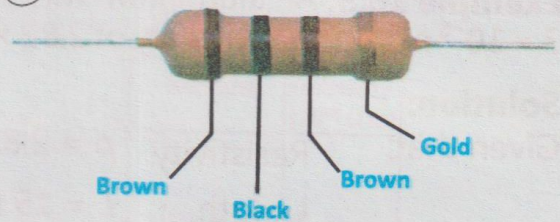

Fig.16.16: 100-ohm resistor colour codes

Table 16.2: Standard resistor colour codes

Colour	Number	Multiplier	Tolerance
Black	0	10^0	-
Brown	1	10^1	-
Red	2	10^2	-
Orange	3	10^3	-
Yellow	4	10^4	-
Green	5	10^5	-
Blue	6	10^6	-
Violet	7	10^7	-
Grey	8	10^8	-
White	9	10^9	-
Gold	-	10^{-2}	$\pm 05\%$
Sliver	-	10^{-1}	$\pm 10\%$
Colourless	-	-	$\pm 20\%$

Negative Temperature Coefficient (NTC) Thermistors

A Negative Temperature Coefficient thermistor (NTC) and its circuit diagram is shown in Fig. 16.17. It is a type of resistor whose resistance decreases as the temperature increases. This behaviour is due to the negative temperature coefficient, meaning that the material used in the thermistor conducts electricity better as the temperature rises. The increase in temperature gives more energy to the charge carriers (electrons), allowing them to move more freely through the material, which reduces the resistance.

Action and Use

As the temperature increases, the resistance of the NTC thermistor decreases. This makes it useful for applications where changes in temperature need to be detected. NTC thermistors are commonly used in

temperature-sensing circuits, such as those found in electronic devices (e.g., thermometers, temperature monitoring circuits, and temperature compensation in circuits).

Applications

1. Temperature sensors in electronic devices.
2. Over current protection in power supplies, where the thermistor can limit current based on temperature changes.

Light-Dependent Resistors (LDRs)

A circuit diagram of a light dependent resistor (LDR) is shown in Fig. 16.18. It is a type of resistor whose resistance decreases as the intensity of light increases. The more light that falls on the LDR, the more current flows through it, as its resistance decreases. This occurs because the photoconductive material inside the LDR absorbs light energy, which excites electrons, allowing them to move more freely and thus reduces the resistance.

Action and Use

As light intensity increases, the resistance of the LDR decreases, allowing more

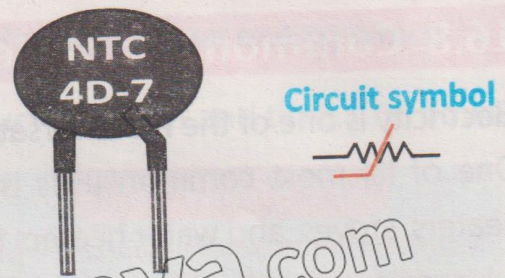

Fig. 16.17: NTC thermistor

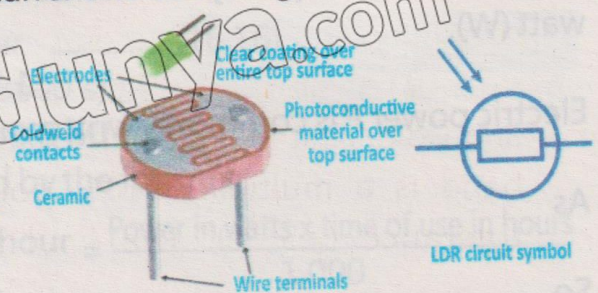

Fig. 16.18: Light dependent resistor

current to pass through. LDRs are widely used in light-sensing circuits, where changes in light intensity are monitored. They are commonly used in automatic lighting systems, brightness sensors in cameras, and other applications where light level detection is needed.

Applications

1. Street lighting that automatically turns ON when it gets dark.
2. Brightness sensors in cameras that adjust exposure based on ambient light levels.

16.8 Common Use of Electricity

Electricity is one of the most versatile forms of energy that is used in our daily lives. One of its most common uses is heating, where it powers devices like electric heaters, stoves, and water heaters to keep us warm and cook our food. It also plays a key role in lighting, from the bulbs in our homes to streetlights and flashlights, making it possible to see and work even after dark. Another important use is battery charging, as electricity powers the chargers for our phones, laptops, electric vehicles, and other portable devices. Additionally, electricity is essential for powering motors, which are found in appliances like washing machines, refrigerators, and industrial machinery, as well as in electric cars and trains. Electricity is the backbone of electronic systems, running computers, televisions, smartphones, and other gadgets that keep us connected and entertained. In short, electricity is everywhere, making our lives easier, safer, and more efficient.

16.9 Electric Power

Electric power is the rate at which electrical energy is transferred or consumed in a circuit.

It measures how quickly work is done or energy is used. The SI unit of power is watt (W).

$$P = W/t$$

$$1 \text{ W} = 1 \text{ J s}^{-1}$$

Electric power P is commonly written as product of current I and voltage V .

$$P = IV \quad \dots\dots\dots (16.13)$$

As

$$V = IR$$

So

$$P = I^2R$$

or

$$P = V^2/R \quad \dots\dots\dots (16.14)$$

Joule's Law

Heat produced by an electric current and the resistance of the conductor can be described by Joule's law. According to this law:

The heat energy produced in a resistance is equal to the product of square of the current, resistance and time.

Mathematically; $H = I^2 R t$
or $H = P \times t$ (16.15)

This is the relationship between electric power P and total heat energy which shows that the total heat energy H is the product of power and time. The power of a resistor determines how quickly heat is produced. For example, a 100 W electric bulb produces heat at a rate of 100 joules per second. The total heat energy depends on how long the electric bulb operates.

Tidbit

Power bills measure energy, not electricity. Our electricity bills show kilowatt-hours (kWh), a measure of energy used, not electricity consumed.

For instance, if the 100 W electric bulb runs for 10 seconds, the total heat energy produced is:

$$H = P \times t = 100 \text{ W} \times 10 \text{ s} = 1,000 \text{ J}$$

Kilowatt-hour

Electrical energy is commonly consumed in very large quantity. The unit which is used to measure large amount of electrical energy is called kilowatt-hour. It is defined as:

The amount of energy delivered by a power of one kilowatt in one hour is called kilowatt-hour.

$$\text{One kilowatt-hour (1 kWh)} = 1,000 \text{ W} \times 1 \text{ hour} \dots\dots\dots (16.16)$$

$$= 1,000 \text{ W} \times (3600 \text{ s})$$

$$= 3.6 \times 10^6 \text{ J} = 3.6 \text{ MJ}$$

The energy in kilowatt-hour can be obtained by the formula:

$$\text{The amount of electrical energy in kilowatt-hour} = \frac{\text{Power in watts} \times \text{time of use in hours}}{1,000}$$

The electric meter installed in our houses measures the consumption of electrical energy in the units of kilowatt-hour according to which we pay our

electricity bills. If the cost of one kilowatt-hour i.e., one unit is known, we can calculate the amount of electricity bill by the formula:

$$\begin{aligned} \text{Cost of electricity} &= \text{Number of units consumed} \times \text{Cost of one unit} \\ &= \frac{\text{Power in watts} \times \text{time of use in hours}}{1,000} \times \text{Cost of one unit} \end{aligned}$$

When designing circuits, it is important to choose components with suitable power ratings. Selecting components with the right power ratings ensures safety, reliability, and efficiency.

Brain Teaser

If two appliances are rated 100 W and 1,000 W, both used for 1 hour. Do they consume equal energy or different? Why?

Example 16.4: Calculate the one-month cost of using a 100 W ceiling fan for 10 hours daily in your room. Assume that the price of one unit is Rs.25.

Solution:

Given that;

Power $P = 100 \text{ W} = 0.1 \text{ kW}$

Time $t = 10 \text{ hour per day}$

Number of days = 30

To find;

One month cost of electricity = ?

$$\begin{aligned} \text{Number of units consumed} &= \text{Power} \times \text{Time} \times \text{Days} \\ &= 0.1 \times 10 \times 30 = 30 \text{ units} \end{aligned}$$

$$\text{Total cost} = \text{Units consumed} \times \text{Price per unit}$$

16.10 Household Circuits and Safety Measures

Household circuits safely distribute electricity through different pathways in a home. Safety measures protect against electrical hazards.

Household Circuits

In a parallel circuit, every appliance like our refrigerator, bulbs, or TV gets its own direct connection to the power supply. In the parallel circuits, each appliance works independently. We can turn OFF the lights in the kitchen without shutting down the

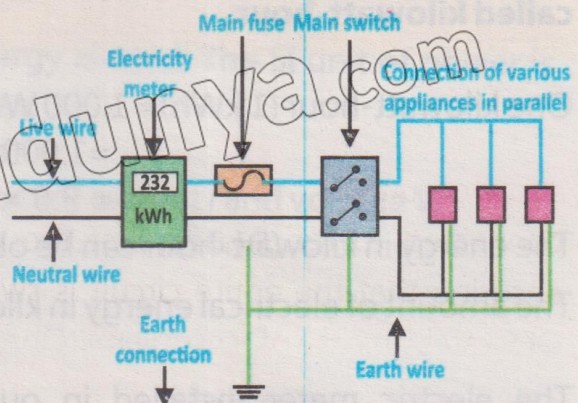

Fig. 16.19: Household circuit

TV in the living room. The parallel circuits are safer and more reliable. If one appliance breaks or a fuse blows, the rest of our home's power stays ON. In short, connecting our home's electrical system in parallel is like giving every appliance its own superpower consistent voltage, independent operation, and reliable performance. It is the smartest way to keep our home running smoothly and efficiently. Figure. 16.19 demonstrates a household circuit.

Hazards of Electricity and Safety Measures

Common electric hazards occur due to:

1. Malpractice (incorrect use) or lack of maintenance, and they can lead to serious accidents like shocks, fires, or even fatalities.
2. One major hazard is damaged insulation, where the protective covering on wires wears out or gets cut, and exposing live wires. This can cause electric shocks or short circuits.
3. Another danger is overheating cables, which happens when wires carry more current than they are designed for, causing them to heat up and potentially start a fire.
4. Overloading is a common issue plugging too many devices into a single socket, extension lead, or power strip can draw excess current, overheating the circuit and causing fires.

Fuses and trip switches (circuit breakers) are essential safety devices to avoid these hazards. Fuses contain a thin wire that melts due to flow of high current. As a result, breaking of the circuit stops the flow of electricity. Different types of fuses are shown in Fig. 16.20. Trip switches, on the other hand, automatically cut OFF power when they detect a fault, like an overload or short circuit (Fig. 16.21). Both devices are connected to the live wire of the circuit, ensuring that the entire circuit is switched OFF safely in case of a problem. One of the most critical safety features in a circuit is the earth wire. If a fault occurs such as a live wire



Fig. 16.20: Different types of fuses

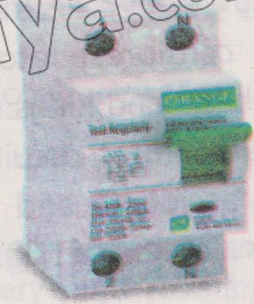

Fig. 16.21: A trip switch

touching a metal casing, the earth wire provides a low-resistance path for the current to flow safely into the ground. This prevents the casing from becoming live and triggers the fuse or trip switch to cut OFF the power. This is why the outer casing of an electrical appliance must be either non-conducting (double-insulated) or earthed. Double-insulated appliances, like many power tools, have casings made of plastic, which cannot conduct electricity. Appliances with metal casings, like washing machines, are connected to the earth wire for safety.

A typical main circuit consists of three wires:

The live wire (line wire), which carries the current from the power supply; the neutral wire, which completes the circuit; and the earth wire, which provides a safety path for fault currents (Fig. 16.22). Despite these safety measures, electric shocks can still occur, and they can be extremely dangerous. When electricity passes through the human body, it can cause burns at the entry and exit points. More seriously, it can disrupt the body's electrical signals, leading to cardiorespiratory failure (where the heart and lungs stop working) or seizures. This is why proper safety mechanisms like fuses, circuit breakers, and earthing are so important which help to prevent accidents and protect lives. The symbols of various electrical components are shown in Fig. 16.23.

Brain Teaser

Why can a tiny device like a smartphone charger trip the main switch if something goes wrong?

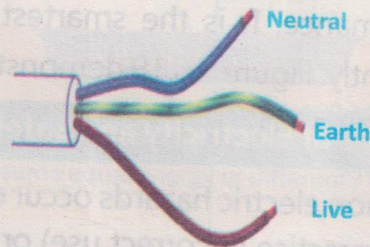

Fig. 16.22: Main circuit wires

Brain Teaser

Imagine your home has no Earth wire. What could happen if the live wire touches the metal body of an appliance?

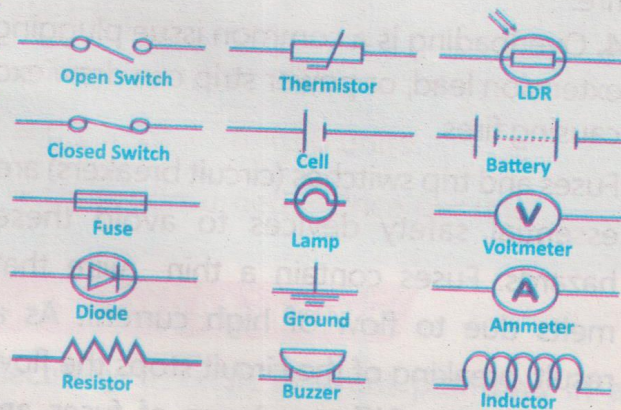

Fig. 16.23: Symbols of various electrical components

EXERCISE

A. Multiple Choice Questions

Tick (✓) the correct answer

- 16.1 The direction of conventional current is:
(a) from negative to positive terminal
(b) from positive to negative terminal
(c) in both directions at the same time
(d) it does not have a fixed direction
- 16.2 What type of electric current flows in one direction only?
(a) Alternating current (b) Direct current
(c) Induced current (d) None of these
- 16.3 The device used to measure electric current:
(a) voltmeter (b) ammeter (c) ohmmeter (d) wattmeter
- 16.4 What is the function of an electromotive force (e.m.f.) source in a circuit?
(a) To reduce resistance in the circuit
(b) To provide energy to drive charges through the circuit
(c) To store electrical energy for later use
(d) To convert electrical energy into mechanical energy
- 16.5 The relationship between voltage, current, and resistance is:
(a) $V = IR$ (b) $V = I/R$ (c) $V = I^2R$ (d) $V = R/I$
- 16.6 What happens to the resistance of a metal conductor when its temperature increases?
(a) It decreases (b) It remains constant
(c) It increases (d) It becomes zero

B. Short Answer Questions

- 16.1 How does an ammeter measure electric current?
- 16.2 What is the main difference between direct current and alternating current?
- 16.3 Define electromotive force (e.m.f.).
- 16.4 State Ohm's law and define resistivity.
- 16.5 What is the formula for calculating the equivalent resistance of resistors connected in series?
- 16.6 How does temperature affect the resistance of a conductor?

C. Constructed Response Questions

- 16.1 Why is it important that an ammeter has very low resistance and is connected in series, while a voltmeter has very high resistance and is connected in parallel? What would happen if they were connected incorrectly?

- 16.2 If a copper wire is replaced with an aluminum wire of the same dimensions, how would the current and power consumption change in the same circuit? Explain using the concept of resistivity.
- 16.3 In a household lighting circuit, what practical problems might arise if the bulbs were connected in series instead of parallel?
- 16.4 You are tasked with designing a fuse for a device that operates at 230 V and 5 A. What rating would you choose for the fuse and why? What could go wrong if the rating is too low or too high?
- 16.5 Explain why A.C is more suitable for power transmission across cities, even though D.C is used in batteries and portable electronic devices.

D. Comprehensive Questions

- 16.1 Explain the concept of electric current. How is it related to the movement of charges, and how is it measured in a circuit?
- 16.2 Define electromotive force (e.m.f.) and potential difference. How does a battery create a potential difference, and what is the role of e.m.f. in maintaining the flow of current?
- 16.3 State and explain Ohm's law. How does the resistance of a conductor affect the flow of current, and how can Ohm's law be applied in practical electrical circuits?
- 16.4 Differentiate between series and parallel combinations of resistors. Provide mathematical expressions for calculating the total resistance in both types of circuits.
- 16.5 What is meant by resistivity of a material? How does it depend on the material, and what role does temperature play in changing the resistivity of conductors and semiconductors?

E. Numerical Problems

- 16.1 A charge of 25 coulombs passes through a circuit in 10 seconds. Calculate the current flowing through the circuit. **[Ans: 2.5 A]**
- 16.2 Three resistors of 4 Ω , 6 Ω , and 8 Ω are connected in series to a 24 V battery. Find the total resistance and the current flowing through the circuit. **[Ans: 18 Ω , 1.33 A]**
- 16.3 Two resistors of 10 Ω and 30 Ω are connected in parallel across a 20 V power supply. Calculate the total resistance and the current drawn from the power supply. **[Ans: 7.5 Ω , 2.67 A]**
- 16.4 Four 1.5 V batteries are connected in series in a flashlight. Determine the total electromotive force (e.m.f.) supplied to the circuit. **[Ans: 6 V]**
- 16.5 A circuit has a 5 A current passing through a 7 Ω resistor. Calculate the power dissipated in the resistor and the energy consumed in 10 minutes. **[Ans: 175 W, 105 kJ]**

flow as long as the chemical reaction is active, providing a steady supply of energy. In short, the chemical action inside the battery creates a potential difference that allows the current in the circuit.

Electric potential (V) is the amount of electric potential energy (W) per unit charge (Q) at a specific point in an electric field.

$$\text{i.e; } V = \frac{W}{Q} \quad \dots\dots\dots (16.4)$$

The potential difference is the difference in the values of electric potential between two points in the electric field (Fig. 16.6). The unit of electric potential is volt (V). One volt equals to one joule per coulomb ($V = J C^{-1}$). Potential difference is also called voltage which is the energy used by a component in the circuit. Voltage can also be referred to e.m.f. which is the energy supplied by a source like a battery. Both potential difference and e.m.f. are measured in volts.

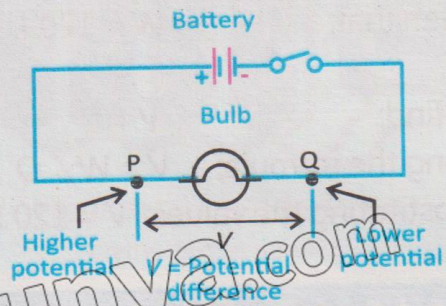

Fig. 16.6: Potential difference across two points in a circuit

Voltmeter

Voltage can be measured using a device called voltmeter. Voltmeter can also be of analog and digital types. Both types are available with different ranges, allowing them to measure voltages of varying magnitudes. Analog voltmeters use a needle and a scale to display the voltage, making them useful for observing changes or trends over time. Digital voltmeters, on the other hand, show the voltage as a numerical value on a screen, offering greater precision and ease of reading. For example, a low-range voltmeter might measure millivolts (mV),

Do You Know?

EMF

Potential difference

VOLTAGE

The electromotive force is the type of energy which forces a unit positive charge to move from the positive to the negative terminal of the source. It separates the two charges from each other.

Voltage is the difference in electric potential between two points. The voltage between two points is equal to the work done per unit of charge against a static electric field to move a test charge between two points.

Analog voltmeter

Digital voltmeter

Fig. 16.7: Types of voltmeters

while a high-range voltmeter could measure hundreds or even thousands of volts. Choosing the right range is important, using a low-range voltmeter for a high voltage could damage the device, while using a high-range voltmeter for a small voltage, might not provide accurate readings. Analog and digital voltmeters are shown in Fig. 16.7.

Example 16.1: A battery does 120 J of work to move a charge of 20 C through a circuit. What is the potential difference across the circuit?

Solution:

Given that; $W = 120 \text{ J}, Q = 20 \text{ C}$

To find; $V = ?$

Using the formula; $V = W / Q$

Substituting the values; $V = 120 \text{ J} / 20 \text{ C} = 6 \text{ V}$

Total E.M.F. of Series Connected Sources

When multiple voltage sources (e.g., batteries) are connected in series (Fig. 16.8), their total electromotive force (e.m.f.) is simply the sum of their individual e.m.f. This is because the voltage sources add energy to the charges one after the other.

Formula:

$$E_{\text{total}} = E_1 + E_2 + \dots + E_n$$

where

E_{total} = total e.m.f.

E_1, E_2, \dots, E_n = e.m.f. of the individual sources

Example: If four batteries, each with an e.m.f. of 1.5 V (Fig. 16.8), are connected in series, the total e.m.f. would be 6 V.

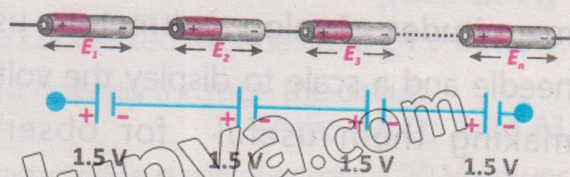

Fig. 16.8: Series combination of batteries

E.M.F. of Identical Sources Connected In Parallel

When multiple identical sources (such as batteries with the same voltage) are connected in parallel (Fig. 16.9), the total e.m.f. across all of them remains equal to the e.m.f. of a single source. This is because, in parallel connections, each

battery is connected directly across the same two points, meaning the voltage (e.m.f.) does not change. However, the total current supplied by the sources will increase due to the additional paths available for current to flow.

Explanation: In a parallel connection, each source contributes current independently while maintaining the same voltage across each of them. This results in the total e.m.f. remaining equal to the e.m.f. of one of the individual sources, but the total current becomes the sum of the individual currents provided by each source.

Formula: For identical sources in parallel:

$$E_{total} = E_1 = E_2 = \dots = E_n$$

where

E_{total} is the total e.m.f. across the parallel sources.

E_1, E_2, \dots, E_n are the e.m.f.'s of the individual sources (which are identical for each source in the parallel connection).

Example: In Fig. 16.9, four 1.5 V batteries are connected in parallel. The total e.m.f. across the combination will still be 1.5 V, just as it is for a single battery.

16.3 Ohm's Law

In 1826, George Simon Ohm made an investigation of the relationship between electric potential difference across a conductor and the current flowing through it. The current in a conductor was increased by increasing the potential difference across its ends. According to Ohm's law;

The current flowing through a conductor is directly proportional to the potential difference V across its two ends of a conductor, provided the physical state (dimension, temperature, etc.) of the conductor remains same.

For Your Information

In a series combination, the total e.m.f. increases, making it easier to push electric charges through the circuit. However, the total current depends on the overall resistance in the circuit.

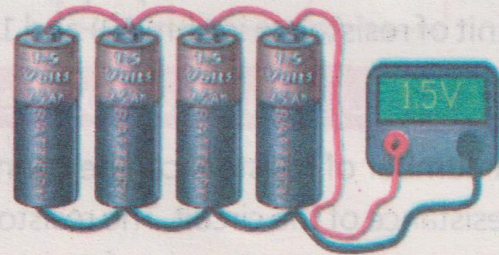

Fig. 16.9: Four 1.5 V batteries connected in parallel.

Brain Teaser

Three identical 5 V cells are connected in parallel. What is the total e.m.f. of the combination?

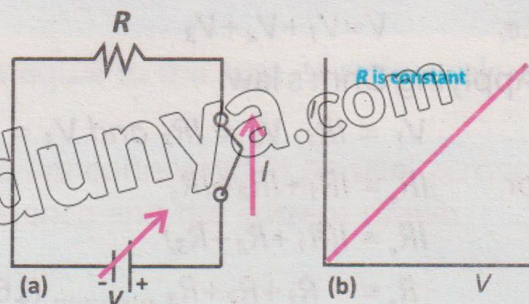

Fig.16.10: (a) Ohm's law circuit (b) I-V graph for ohmic conductor

Mathematically;

$$I \propto V$$
$$I = \frac{1}{R} V$$

$$V = IR \quad \dots\dots\dots (16.5)$$

where R is constant of proportionality called resistance of a conductor. The SI unit of resistance is ohm (Ω) and $1 \Omega = V A^{-1}$.

16.4 Combination of Resistances

A number of resistors can be connected in a circuit to increase or decrease the net resistance of the circuit. The resistors are connected either in series or in parallel and the equivalent resistance of the circuit depends upon the type of combination.

Series Combination of Resistors

When resistors are connected in such a way that there is only one path for the current to flow, then it is called series combination of resistors. For example, consider three resistors R_1 , R_2 and R_3 connected in series as shown in Fig. 16.11. When this combination is connected to a battery of V volts, it draws current I from the battery. Let R_e be a single resistor representing the total resistance of the circuit, also called equivalent resistance.

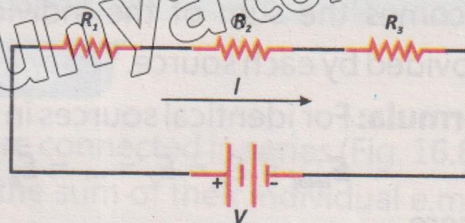

Fig.16.11: Resistors in series

The total voltage in the circuit will be the sum of voltage across the three resistors.

i.e; $V = V_1 + V_2 + V_3$

Applying Ohm's law:

$$V_1 = IR_1, V_2 = IR_2 \text{ and } V_3 = IR_3$$

or $IR_e = IR_1 + IR_2 + IR_3$

$$IR_e = I(R_1 + R_2 + R_3)$$

$$R_e = R_1 + R_2 + R_3 \quad \dots\dots\dots (16.6)$$

Thus, equivalent resistance is equal to the sum of individual resistances.

Parallel Combination of Resistors

When there are multiple paths for current flow in a circuit (as indicated in the diagram), the combination of resistances is referred to as parallel combination. The electric potential across each resistance is the same and equal to the applied potential. Each resistor has a steady current flowing through it. Consider three resistors R_1 , R_2 and R_3 connected in parallel (Fig. 16.12). When these are connected to a battery of V volts, it draws a current I from the battery. R_e is a single resistor. This resistor is such that when it is connected to the same battery of V volts, it also draws current I from the battery. This resistor is therefore called equivalent resistor and its resistance is called equivalent resistance. The total current in the circuit will be the sum of currents flowing through the resistors;

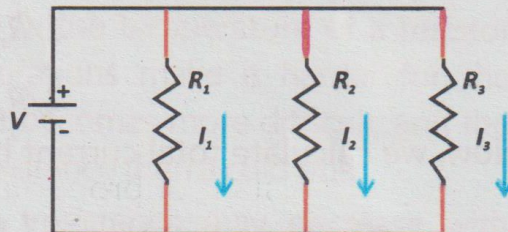

Fig.16.12: Resistors in parallel

$$I = I_1 + I_2 + I_3$$

Applying Ohm's law

$$V = I_1 R_1, \quad V = I_2 R_2, \quad V = I_3 R_3$$

or
$$I_1 = \frac{V}{R_1}, \quad I_2 = \frac{V}{R_2}, \quad I_3 = \frac{V}{R_3}$$

or
$$\frac{V}{R_e} = \frac{V}{R_1} + \frac{V}{R_2} + \frac{V}{R_3}$$

or
$$\frac{V}{R_e} = V \left[\frac{1}{R_1} + \frac{1}{R_2} + \frac{1}{R_3} \right]$$

$$\frac{1}{R_e} = \frac{1}{R_1} + \frac{1}{R_2} + \frac{1}{R_3} \quad \dots\dots\dots (16.7)$$

Tip
Birds are safe because both their feet touch the same potential wire. There is no voltage difference, so no current flows through their bodies.

Thus, the reciprocal of equivalent resistance is equal to the sum of reciprocals of individual resistances.

Example 16.2: Two resistors of 8Ω and 24Ω are connected in parallel across a 30 V power supply. Calculate the total resistance and the current drawn from the power supply.

Solution:

Given that; $R_1 = 8 \Omega$, $R_2 = 24 \Omega$ and $V = 30 \text{ V}$

To find; $R_e = ?$ and $I = ?$

Using the formula for parallel resistance: $1/R_e = 1/R_1 + 1/R_2$
 Substituting the values; $1/R_e = (1/8) + (1/24)$

$$1/R_e = (3/24) + (1/24)$$

$$1/R_e = 4/24 \text{ or } R_e = 24/4 = 6 \Omega$$

Now, we calculate total current by using Ohm's Law:

$$I = V/R_e = 30 \text{ V} / 6 \Omega = 5 \text{ A}$$

16.5 Electrical Resistivity

The opposition to the flow of electric current is called resistance.

This resistance is directly proportional to the length of the conductor and inversely proportional to its area. If A is the area and R is the resistance of a conductor (Fig. 16.13), then mathematically we can write it as:

$$R \propto L \text{ or } R \propto \frac{L}{A}$$

$$R = \rho \frac{L}{A}$$

$$R = \rho \frac{L}{A} \dots\dots (16.8)$$

Here, ρ is a constant called electrical resistivity of a material which quantifies how strongly a material resists to electric current. Materials with high resistivity are poor conductors of electricity, while those with low resistivity are good conductors. The SI unit of resistivity is the ohm-metre ($\Omega \text{ m}$).

Resistance of a cubic metre of a material is called resistivity.

Effect of Temperature on Resistance of a Conductor

The resistance and the resistivity of a conductor can change with temperature. In most conductors such as metals, the electrical resistance increases with temperature because atomic vibrations resist electron flow.

For example, in a filament lamp, when the

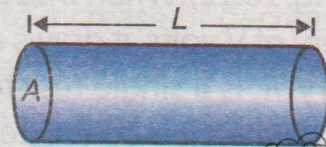

Fig. 16.13: Resistivity of a material

Table 16.1: Electrical resistivity of different materials

Material	Electrical resistivity ($10^{-8} \Omega \text{ m}$)
Silver	1.7
Copper	1.69
Aluminium	2.75
Tungsten	5.25
Platinum	10.6
Iron	9.8
Nichrome	100
Graphite	3500

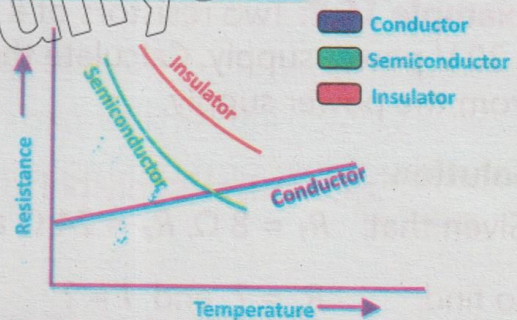

Fig.16.14: Temperature effect on materials

temperature of the filament (resistor) increases, its resistance also increases. This occurs because the filament is made of metal, and metals have free electrons that causes the flow of electric current. The increase in the temperature of a resistor increases the vibration of its atoms. These vibrations make it harder for the electrons to move. As a result, the flow of current becomes more difficult, and the resistance goes up. So, a hot filament has more resistance than a cold one.

In the case of semiconductors and insulators, resistance may decrease with temperature due to increase in the mobility of free charge carriers. For example, thermistor, which is made up of a semiconductor material, is a type of resistor whose resistance decreases as its temperature increases. At low temperatures, the semiconductor material has fewer free charge carriers (electrons or holes), resulting in high resistance. As the temperature rises, more charge carriers are released, increasing conductivity and reducing resistance. Due to change in resistance, the resistivity also changes accordingly. The effect of temperature on resistance of different materials is graphically shown in Fig. 16.14.

Example 16.3: An aluminium wire has a length of 15 m, a cross-sectional area of $3 \times 10^{-6} \text{ m}^2$, and a resistivity of $2.82 \times 10^{-8} \Omega \text{ m}$. Calculate its resistance.

Solution:

Given that;

Resistivity $\rho = 2.82 \times 10^{-8} \Omega \text{ m}$

Length $L = 15 \text{ m}$, $A = 3 \times 10^{-6} \text{ m}^2$

To find;

Resistance $R = ?$

Using the formula:

$$R = \rho (L / A)$$

Substituting the values

$$R = (2.82 \times 10^{-8} \Omega \text{ m}) \times (15 \text{ m} / 3 \times 10^{-6} \text{ m}^2)$$

$$R = (2.82 \times 10^{-8}) \times (5 \times 10^6)$$

$$R = 0.141 \Omega$$

The resistance of the wire is 0.141Ω .

16.6 Potential Divider Circuit

A potential or voltage divider is a circuit that divides a voltage into smaller parts using resistors. It consists of two or more resistors connected in series across a voltage source (Fig. 16.15). The voltage across each resistor is proportional to its resistance relative to the total resistance of the circuit.

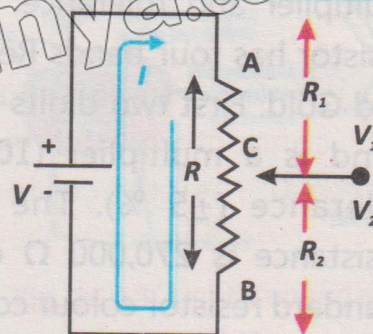

Fig.16.15: Potential divider circuit

Consider two resistors R_1 and R_2 connected in series. The voltage across each resistor is given by

$$\frac{R_1}{R_2} = \frac{V_1}{V_2} \dots\dots\dots (16.9)$$

where V_1 = voltage across R_1
and V_2 = voltage across R_2

The total voltage (V_{total}) is the sum of V_1 and V_2 :

$$V_{\text{total}} = V_1 + V_2 \dots\dots\dots (16.10)$$

The voltage across each resistor can also be calculated using the formulae:

$$V_1 = IR_1 = \frac{V_{\text{total}}}{R_e} \times R_1$$

$$V_1 = V_{\text{total}} \times \frac{R_1}{R_1 + R_2} \dots\dots\dots (16.11)$$

Similarly

$$V_2 = V_{\text{total}} \times \frac{R_2}{R_1 + R_2} \dots\dots\dots (16.12)$$

16.7 Resistor Colour Codes

The resistor colour codes is a system of coloured bands printed on resistors to indicate their resistance value and tolerance (Fig.16.16). Tolerance means how much a resistor's real value can be different from the value written on it. In this way, resistor's values can be identified without using multimeter. Each colour represents a specific digit and multiplier. In a four band resistor, the first and second bands indicate 1st and 2nd digit, the 3rd and 4th bands show multiplier and tolerance. For example, a resistor has four bands Red, Violet, Yellow and Gold. First two digits show 27, Yellow band is a multiplier (10^4), gold shows tolerance ($\pm 5\%$). The final value of resistance is 270,000 Ω or 270 k Ω . The standard resistor colour codes are given in Table 16.2.

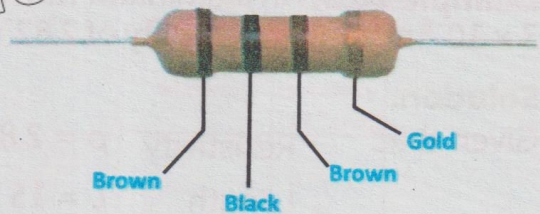

Fig.16.16: 100-ohm resistor colour codes

Table 16.2: Standard resistor colour codes

Colour	Number	Multiplier	Tolerance
Black	0	10^0	-
Brown	1	10^1	-
Red	2	10^2	-
Orange	3	10^3	-
Yellow	4	10^4	-
Green	5	10^5	-
Blue	6	10^6	-
Violet	7	10^7	-
Grey	8	10^8	-
White	9	10^9	-
Gold	-	10^{-2}	$\pm 05\%$
Sliver	-	10^{-1}	$\pm 10\%$
Colourless	-	-	$\pm 20\%$

Negative Temperature Coefficient (NTC) Thermistors

A Negative Temperature Coefficient thermistor (NTC) and its circuit diagram is shown in Fig. 16.17. It is a type of resistor whose resistance decreases as the temperature increases. This behaviour is due to the negative temperature coefficient, meaning that the material used in the thermistor conducts electricity better as the temperature rises. The increase in temperature gives more energy to the charge carriers (electrons), allowing them to move more freely through the material, which reduces the resistance.

Action and Use

As the temperature increases, the resistance of the NTC thermistor decreases. This makes it useful for applications where changes in temperature need to be detected. NTC thermistors are commonly used in

temperature-sensing circuits, such as those found in electronic devices (e.g., thermometers, temperature monitoring circuits, and temperature compensation in circuits).

Applications

1. Temperature sensors in electronic devices.
2. Over current protection in power supplies, where the thermistor can limit current based on temperature changes.

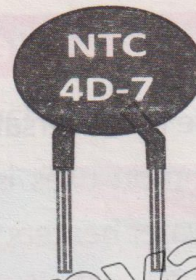

Circuit symbol

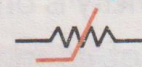

Fig. 16.17: NTC thermistor

Light-Dependent Resistors (LDRs)

A circuit diagram of a light dependent resistor (LDR) is shown in Fig. 16.18. It is a type of resistor whose resistance decreases as the intensity of light increases. The more light that falls on the LDR, the more current flows through it, as its resistance decreases. This occurs because the photoconductive material inside the LDR absorbs light energy, which excites electrons, allowing them to move more freely and thus reduces the resistance.

Action and Use

As light intensity increases, the resistance of the LDR decreases, allowing more



Fig. 16.18: Light dependent resistor

current to pass through. LDRs are widely used in light-sensing circuits, where changes in light intensity are monitored. They are commonly used in automatic lighting systems, brightness sensors in cameras, and other applications where light level detection is needed.

Applications

1. Street lighting that automatically turns ON when it gets dark.
2. Brightness sensors in cameras that adjust exposure based on ambient light levels.

16.8 Common Use of Electricity

Electricity is one of the most versatile forms of energy that is used in our daily lives. One of its most common uses is heating, where it powers devices like electric heaters, stoves, and water heaters to keep us warm and cook our food. It also plays a key role in lighting, from the bulbs in our homes to streetlights and flashlights, making it possible to see and work even after dark. Another important use is battery charging, as electricity powers the chargers for our phones, laptops, electric vehicles, and other portable devices. Additionally, electricity is essential for powering motors, which are found in appliances like washing machines, refrigerators, and industrial machinery, as well as in electric cars and trains. Electricity is the backbone of electronic systems, running computers, televisions, smartphones, and other gadgets that keep us connected and entertained. In short, electricity is everywhere, making our lives easier, safer, and more efficient.

16.9 Electric Power

Electric power is the rate at which electrical energy is transferred or consumed in a circuit.

It measures how quickly work is done or energy is used. The SI unit of power is watt (W).

$$P = W/t$$

$$1 \text{ W} = 1 \text{ J s}^{-1}$$

Electric power P is commonly written as product of current I and voltage V .

$$P = IV \quad \dots\dots\dots (16.13)$$

As

$$V = IR$$

So

$$P = I^2R$$

or

$$P = V^2/R \quad \dots\dots\dots (16.14)$$

Joule's Law

Heat produced by an electric current and the resistance of the conductor can be described by Joule's law. According to this law:

The heat energy produced in a resistance is equal to the product of square of the current, resistance and time.

Mathematically;

$$H = I^2 R t$$

or

$$H = P \times t \dots\dots\dots (16.15)$$

This is the relationship between electric power P and total heat energy which

shows that the total heat energy H is the product of power and time. The power of a resistor determines how quickly heat is produced. For example, a 100 W electric bulb produces heat at a rate of 100 joules per second. The total heat energy depends on how long the electric bulb operates.

Tidbit

Power bills measure energy, not electricity. Our electricity bills show kilowatt-hours (kWh), a measure of energy used, not electricity consumed.

For instance, if the 100 W electric bulb runs for 10 seconds, the total heat energy produced is:

$$H = P \times t = 100 \text{ W} \times 10 \text{ s} = 1,000 \text{ J}$$

Kilowatt-hour

Electrical energy is commonly consumed in very large quantity. The unit which is used to measure large amount of electrical energy is called kilowatt-hour. It is defined as:

The amount of energy delivered by a power of one kilowatt in one hour is called kilowatt-hour.

$$\begin{aligned} \text{One kilowatt-hour (1 kWh)} &= 1,000 \text{ W} \times 1 \text{ hour} \dots\dots\dots (16.16) \\ &= 1,000 \text{ W} \times (3600 \text{ s}) \\ &= 3.6 \times 10^6 \text{ J} = 3.6 \text{ MJ} \end{aligned}$$

The energy in kilowatt-hour can be obtained by the formula:

$$\text{The amount of electrical energy in kilowatt-hour} = \frac{\text{Power in watts} \times \text{time of use in hours}}{1,000}$$

The electric meter installed in our houses measures the consumption of electrical energy in the units of kilowatt-hour according to which we pay our

electricity bills. If the cost of one kilowatt-hour i.e., one unit is known, we can calculate the amount of electricity bill by the formula:

$$\text{Cost of electricity} = \frac{\text{Number of units consumed} \times \text{Cost of one unit}}{1,000} \times \text{Cost of one unit}$$

$$= \frac{\text{Power in watts} \times \text{time of use in hours}}{1,000} \times \text{Cost of one unit}$$

When designing circuits, it is important to choose components with suitable power ratings. Selecting components with the right power ratings ensures safety, reliability, and efficiency.

Brain Teaser

If two appliances are rated 100 W and 1,000 W, both used for 1 hour. Do they consume equal energy or different? Why?

Example 16.4: Calculate the one-month cost of using a 100 W ceiling fan for 10 hours daily in your room. Assume that the price of one unit is Rs.25.

Solution:

Given that;

Power $P = 100 \text{ W} = 0.1 \text{ kW}$

Time $t = 10 \text{ hour per day}$

Number of days = 30

To find;

One month cost of electricity = ?

Number of units consumed = Power \times Time \times Days

= $0.1 \times 10 \times 30 = 30 \text{ units}$

Total cost = Units consumed \times Price per unit

16.10 Household Circuits and Safety Measures

Household circuits safely distribute electricity through different pathways in a home. Safety measures protect against electrical hazards.

Household Circuits

In a parallel circuit, every appliance like our refrigerator, bulbs, or TV gets its own direct connection to the power supply. In the parallel circuits, each appliance works independently. We can turn OFF the lights in the kitchen without shutting down the

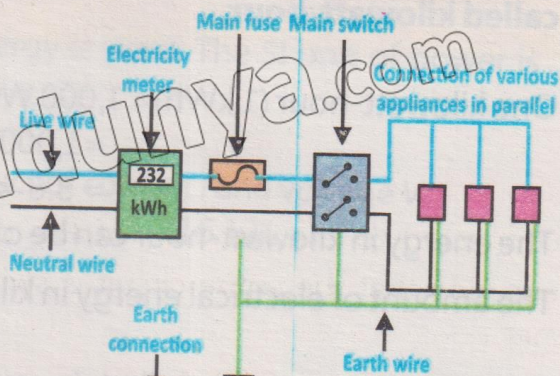

Fig. 16.19: Household circuit

TV in the living room. The parallel circuits are safer and more reliable. If one appliance breaks or a fuse blows, the rest of our home's power stays ON. In short, connecting our home's electrical system in parallel is like giving every appliance its own superpower consistent voltage, independent operation, and reliable performance. It is the smartest way to keep our home running smoothly and efficiently. Figure. 16.19 demonstrates a household circuit.

Hazards of Electricity and Safety Measures

Common electric hazards occur due to:

1. Malpractice (incorrect use) or lack of maintenance, and they can lead to serious accidents like shocks, fires, or even fatalities.
2. One major hazard is damaged insulation, where the protective covering on wires wears out or gets cut, and exposing live wires. This can cause electric shocks or short circuits.
3. Another danger is overheating cables, which happens when wires carry more current than they are designed for, causing them to heat up and potentially start a fire.
4. Overloading is a common issue plugging too many devices into a single socket, extension lead, or power strip can draw excess current, overheating the circuit and causing fires.

Fuses and trip switches (circuit breakers) are essential safety devices to avoid these hazards. Fuses contain a thin wire that melts due to flow of high current. As a result, breaking of the circuit stops the flow of electricity. Different types of fuses are shown in Fig. 16.20. Trip switches, on the other hand, automatically cut OFF power when they detect a fault, like an overload or short circuit (Fig. 16.21). Both devices are connected to the live wire of the circuit, ensuring that the entire circuit is switched OFF safely in case of a problem. One of the most critical safety features in a circuit is the earth wire. If a fault occurs such as a live wire



Fig. 16.20: Different types of fuses



Fig. 16.21: A trip switch

touching a metal casing, the earth wire provides a low-resistance path for the current to flow safely into the ground. This prevents the casing from becoming live and triggers the fuse or trip switch to cut OFF the power. This is why the outer casing of an electrical appliance must be either non-conducting (double-insulated) or earthed. Double-insulated appliances, like many power tools, have casings made of plastic, which cannot conduct electricity. Appliances with metal casings, like washing machines, are connected to the earth wire for safety.

A typical main circuit consists of three wires:

The live wire (line wire), which carries the current from the power supply; the neutral wire, which completes the circuit; and the earth wire, which provides a safety path for fault currents (Fig. 16.22). Despite these safety measures, electric shocks can still occur, and they can be extremely dangerous. When electricity passes through the human body, it can cause burns at the entry and exit points. More seriously, it can disrupt the body's electrical signals, leading to cardiorespiratory failure (where the heart and lungs stop working) or seizures. This is why proper safety mechanisms like fuses, circuit breakers, and earthing are so important which help to prevent accidents and protect lives. The symbols of various electrical components are shown in Fig. 16.23.

Brain Teaser

Why can a tiny device like a smartphone charger trip the main switch if something goes wrong?

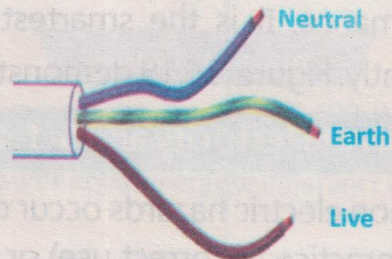

Fig. 16.22: Main circuit wires

Brain Teaser

Imagine your home has no Earth wire. What could happen if the live wire touches the metal body of an appliance?

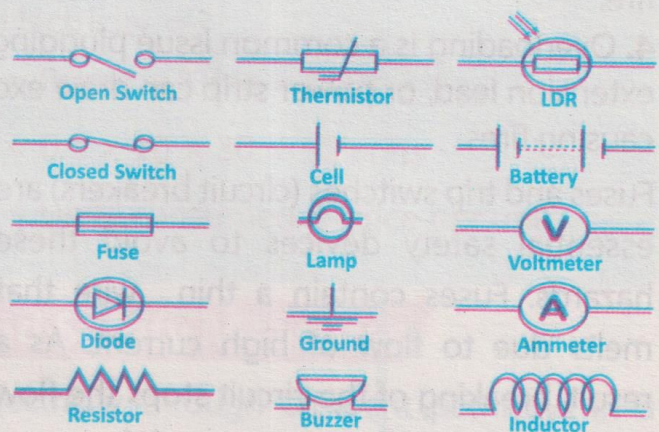

Fig. 16.23: Symbols of various electrical components

EXERCISE

A. Multiple Choice Questions

Tick (✓) the correct answer

- 16.1 The direction of conventional current is:
(a) from negative to positive terminal
(b) from positive to negative terminal
(c) in both directions at the same time
(d) it does not have a fixed direction
- 16.2 What type of electric current flows in one direction only?
(a) Alternating current (b) Direct current
(c) Induced current (d) None of these
- 16.3 The device used to measure electric current:
(a) voltmeter (b) ammeter (c) ohmmeter (d) wattmeter
- 16.4 What is the function of an electromotive force (e.m.f.) source in a circuit?
(a) To reduce resistance in the circuit
(b) To provide energy to drive charges through the circuit
(c) To store electrical energy for later use
(d) To convert electrical energy into mechanical energy
- 16.5 The relationship between voltage, current, and resistance is:
(a) $V = IR$ (b) $V = I/R$ (c) $V = I^2 R$ (d) $V = R/I$
- 16.6 What happens to the resistance of a metal conductor when its temperature increases?
(a) It decreases (b) It remains constant
(c) It increases (d) It becomes zero

B. Short Answer Questions

- 16.1 How does an ammeter measure electric current?
- 16.2 What is the main difference between direct current and alternating current?
- 16.3 Define electromotive force (e.m.f.).
- 16.4 State Ohm's law and define resistivity.
- 16.5 What is the formula for calculating the equivalent resistance of resistors connected in series?
- 16.6 How does temperature affect the resistance of a conductor?

C. Constructed Response Questions

- 16.1 Why is it important that an ammeter has very low resistance and is connected in series, while a voltmeter has very high resistance and is connected in parallel? What would happen if they were connected incorrectly?

- 16.2 If a copper wire is replaced with an aluminum wire of the same dimensions, how would the current and power consumption change in the same circuit? Explain using the concept of resistivity.
- 16.3 In a household lighting circuit, what practical problems might arise if the bulbs were connected in series instead of parallel?
- 16.4 You are tasked with designing a fuse for a device that operates at 230 V and 5 A. What rating would you choose for the fuse and why? What could go wrong if the rating is too low or too high?
- 16.5 Explain why A.C is more suitable for power transmission across cities, even though D.C is used in batteries and portable electronic devices.

D. Comprehensive Questions

- 16.1 Explain the concept of electric current. How is it related to the movement of charges, and how is it measured in a circuit?
- 16.2 Define electromotive force (e.m.f.) and potential difference. How does a battery create a potential difference, and what is the role of e.m.f. in maintaining the flow of current?
- 16.3 State and explain Ohm's law. How does the resistance of a conductor affect the flow of current, and how can Ohm's law be applied in practical electrical circuits?
- 16.4 Differentiate between series and parallel combinations of resistors. Provide mathematical expressions for calculating the total resistance in both types of circuits.
- 16.5 What is meant by resistivity of a material? How does it depend on the material, and what role does temperature play in changing the resistivity of conductors and semiconductors?

E. Numerical Problems

- 16.1 A charge of 25 coulombs passes through a circuit in 10 seconds. Calculate the current flowing through the circuit. **[Ans: 2.5 A]**
- 16.2 Three resistors of $4\ \Omega$, $6\ \Omega$, and $8\ \Omega$ are connected in series to a 24 V battery. Find the total resistance and the current flowing through the circuit. **[Ans: 18 Ω , 1.33 A]**
- 16.3 Two resistors of $10\ \Omega$ and $30\ \Omega$ are connected in parallel across a 20 V power supply. Calculate the total resistance and the current drawn from the power supply. **[Ans: 7.5 Ω , 2.67 A]**
- 16.4 Four 1.5 V batteries are connected in series in a flashlight. Determine the total electromotive force (e.m.f.) supplied to the circuit. **[Ans: 6 V]**
- 16.5 A circuit has a 5 A current passing through a $7\ \Omega$ resistor. Calculate the power dissipated in the resistor and the energy consumed in 10 minutes. **[Ans: 175 W, 105 kJ]**